

# Ranger "10"

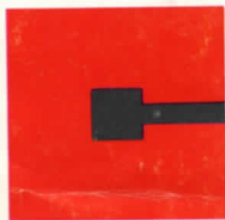

**CLEBURNE TRUCK & BODY SALES, INCORPORATED**  
1803 North Main ■ Cleburne, Texas 76031 ■ 817-645-3972

# LOADING

- 10 SECOND PACKING CYCLE
- LOW LOADING HEIGHT



10 SECOND PACKING CYCLE



**LOW LOADING HEIGHT** — 5" below truck frame. Hopper capacity 1¼ cubic yards. Container attachment available.

# Ranger

FAST

ECONOMY

VERSATILE

10 cubic yards

DESIGNED FOR

Independent

Park System

Highway De

Narrow Alle

Short Turn

Industrial F

Towns and

# DUMPING

- FULL CLEAN EJECTION UNLOADING

over 10"

OMICAL  
RSATILE

ds capacity

nt Haulers

ems

epartments

eys

Arounds

Plants

d Cities



**EJECTION UNLOADING** — At the disposal point, the operator simply raises the tailgate, pushes the ejection lever control, and the ejection panel pushes the load out of the body. Ejection time 12 seconds.

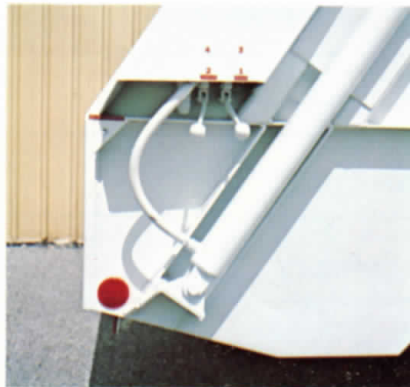

**PACKING CONTROLS** — Manual controls located on right hand rear of body.

**EJECTION CONTROLS** — Manual controls located on left hand front of body.



# SPECIFICATIONS

# Ranger "10"

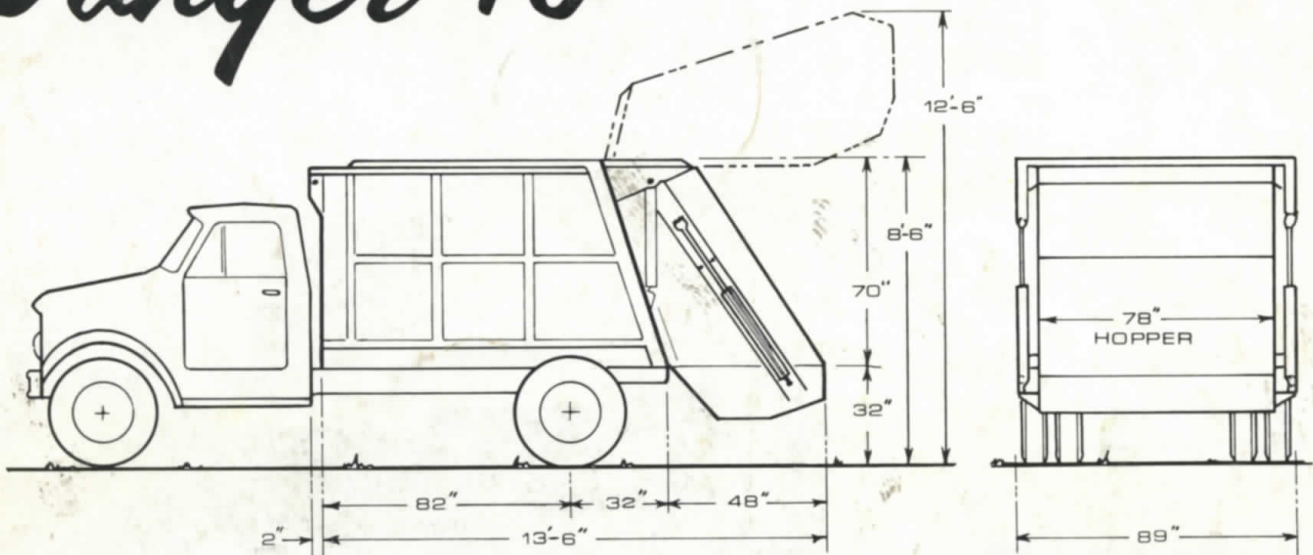

UNIT CAPACITY	10 CUBIC YARDS
BODY LENGTH	13' - 6"
OUTSIDE WIDTH	92"
BODY HEIGHT	8' - 6"
PACKING CYCLE	10 SECONDS
HOPER CAPACITY	1¼ CUBIC YARDS
WEIGHT	6250 LBS.
CAB-TO-AXLE (Recommended)	84" to 90"
G. V. W. (Recommended)	17,000 LBS.

DISTRIBUTED BY

**GAR WOOD-BOSTON  
TRUCK EQUIPMENT, INC**  
316 NORTH BEACON STREET  
BRIGHTON, MASS. 02135  
STadium 2-4320