

THE ORIGINAL UNITIZED SIDE LOADER BODY

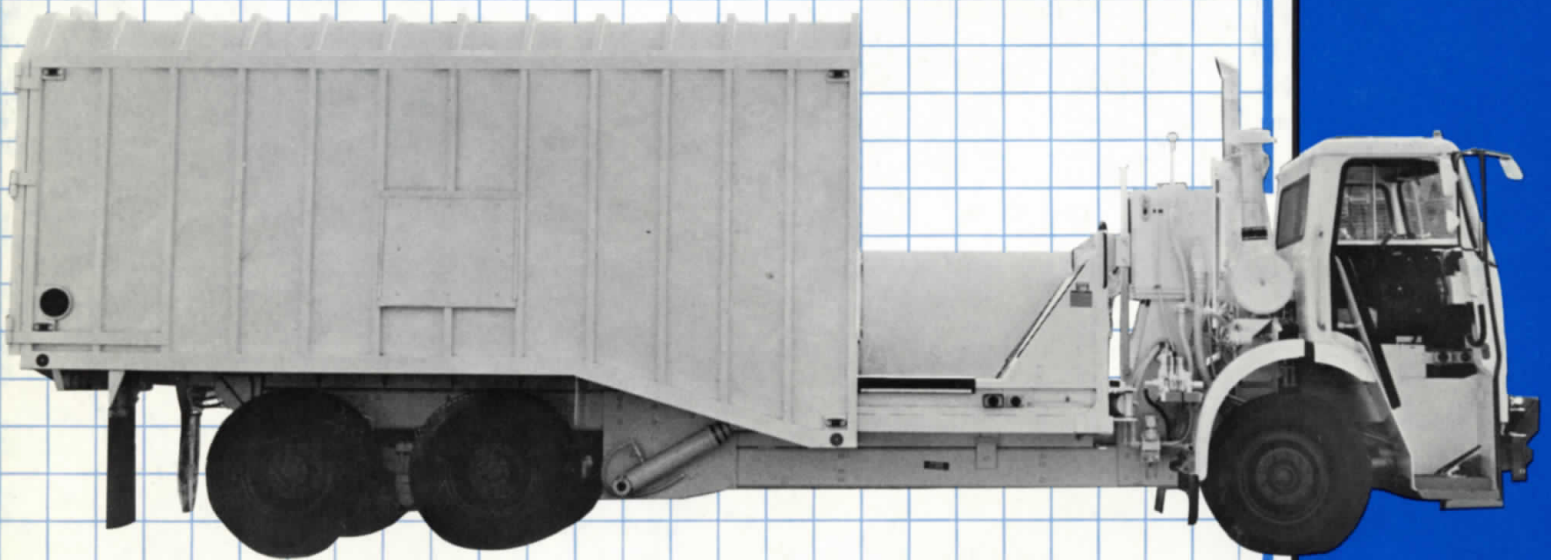

8700 SANTA FE AVENUE
SOUTH GATE, CALIFORNIA 90280



THE ORIGINAL UNITIZED SIDE

Amrep's Side Loader is designed to allow the operator to get large, high density payloads with ease.

Amrep's Side Loaders are available in 25 thru 37 cubic yard capacities.

Options are available on request.

CLOSELY SPACED POSTS

ONE PIECE CARLAN ALLOW WATER TO DRAIN OFF ROOF

TRIPLE OVER CENTER DOOR LATCH HANDLES

SAFETY FLASHER LIGHTS - STANDARD

EASILY REPAIRED HOIST CYLINDERS

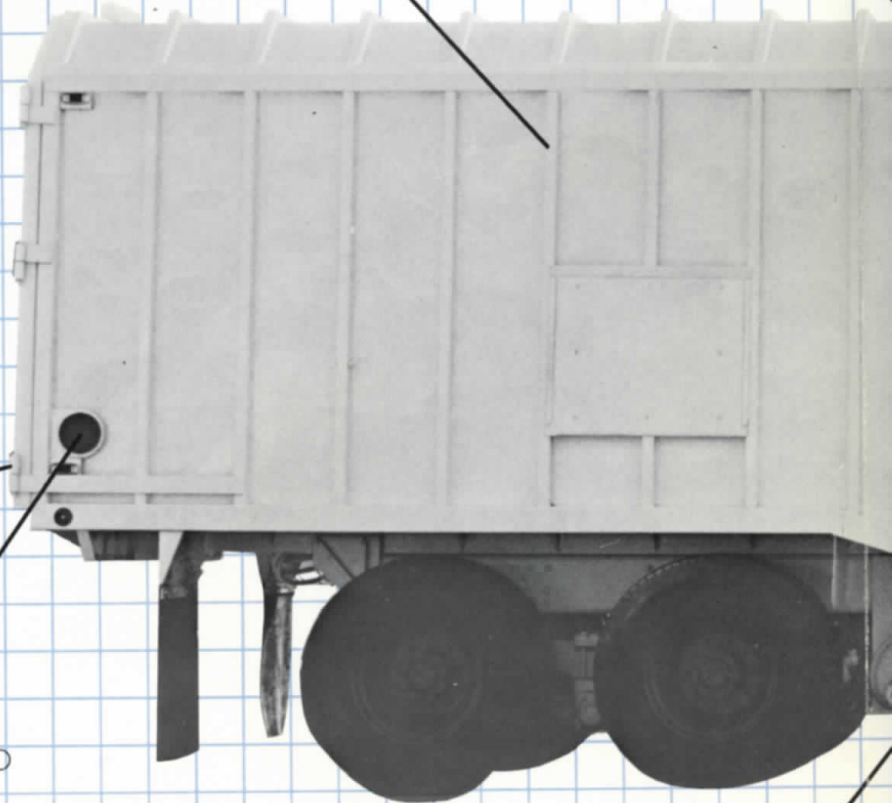

DE LOADER BODY

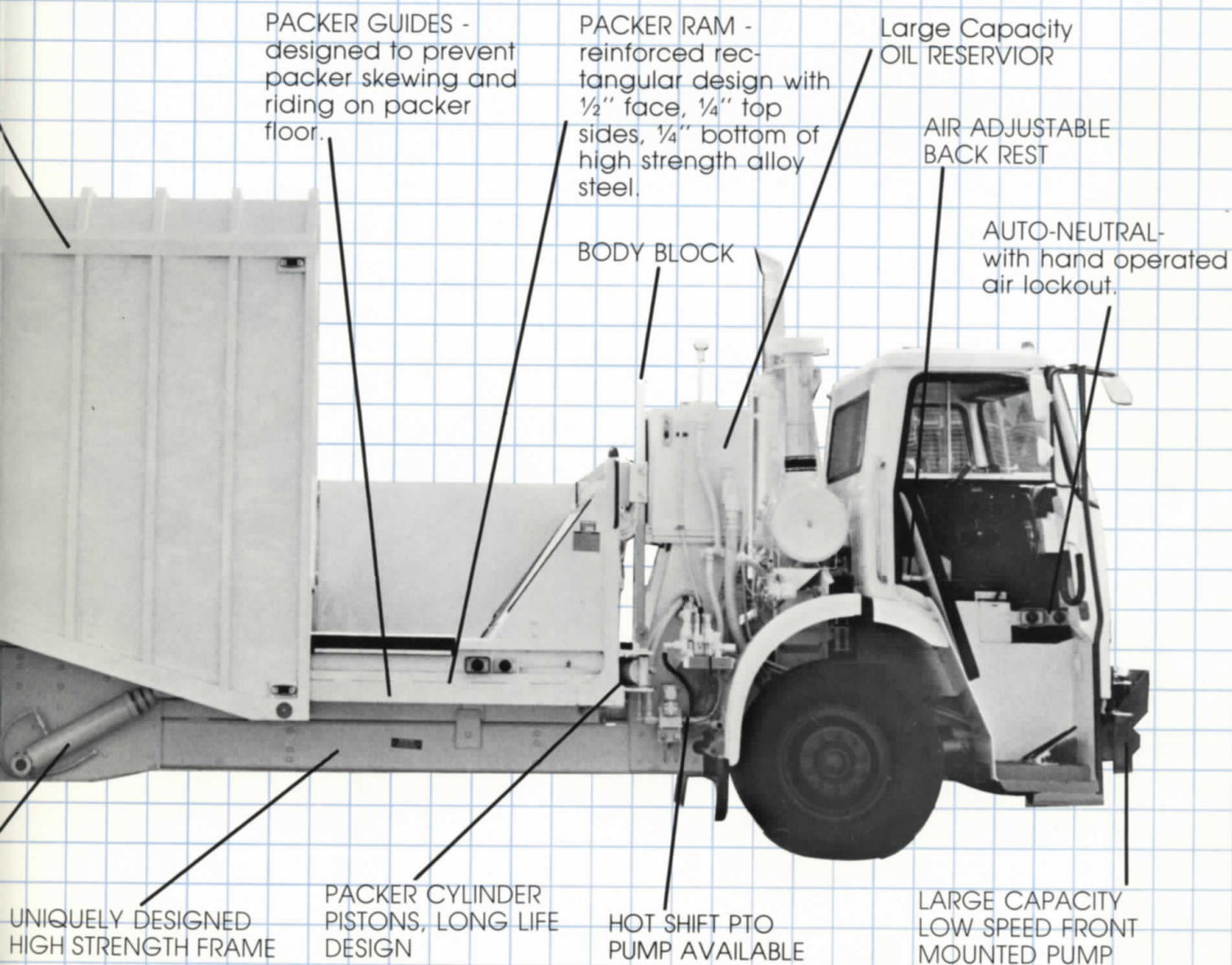

PACKER GUIDES -
designed to prevent
packer skewing and
riding on packer
floor.

PACKER RAM -
reinforced rec-
tangular design with
1/2" face, 1/4" top
sides, 1/4" bottom of
high strength alloy
steel.

Large Capacity
OIL RESERVIOR

AIR ADJUSTABLE
BACK REST

AUTO-NEUTRAL-
with hand operated
air lockout.

BODY BLOCK

UNIQUELY DESIGNED
HIGH STRENGTH FRAME

PACKER CYLINDER
PISTONS, LONG LIFE
DESIGN

HOT SHIFT PTO
PUMP AVAILABLE

LARGE CAPACITY
LOW SPEED FRONT
MOUNTED PUMP

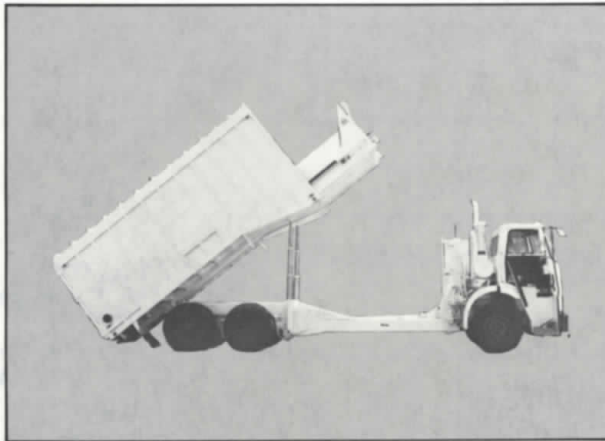

AMREP SIDE LOADER



AMREP OCTAGONAL



AMREP ROLL-OFF

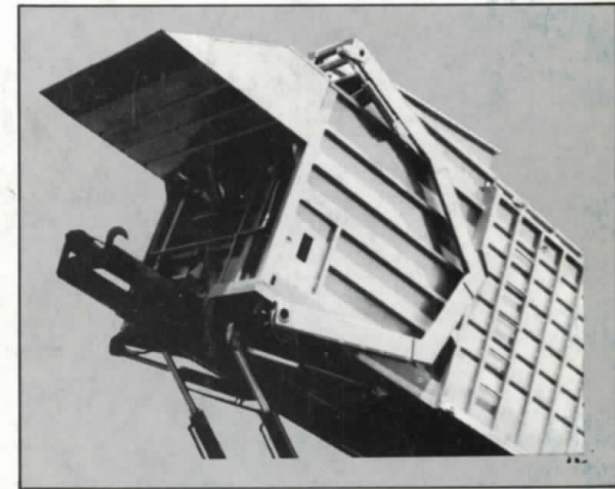

AMREP ROLL-OFF FRONT LOADER



8700 SANTA FE AVENUE
SOUTH GATE, CALIFORNIA 90280
(213) 583-6851