

FRONT LOADING REFUSE PACKER

OFFERING

↘ SIZE AND EQUIPMENT OPTIONS

↘ HEAVY DUTY CONSTRUCTION THROUGHOUT

↘ EQUIPMENT FLEXIBILITY TO MEET YOUR SPEC.

↘ YEARS OF PROVEN PERFORMANCE



84-

MANUFACTURING SALES & SERVICE BY

S. VINCEN BOWLES, INC.

12039 Branford St., Sun Valley, California
Phone 899-9511 Area Code 213

STANDARD UNIT SPECIFICATIONS

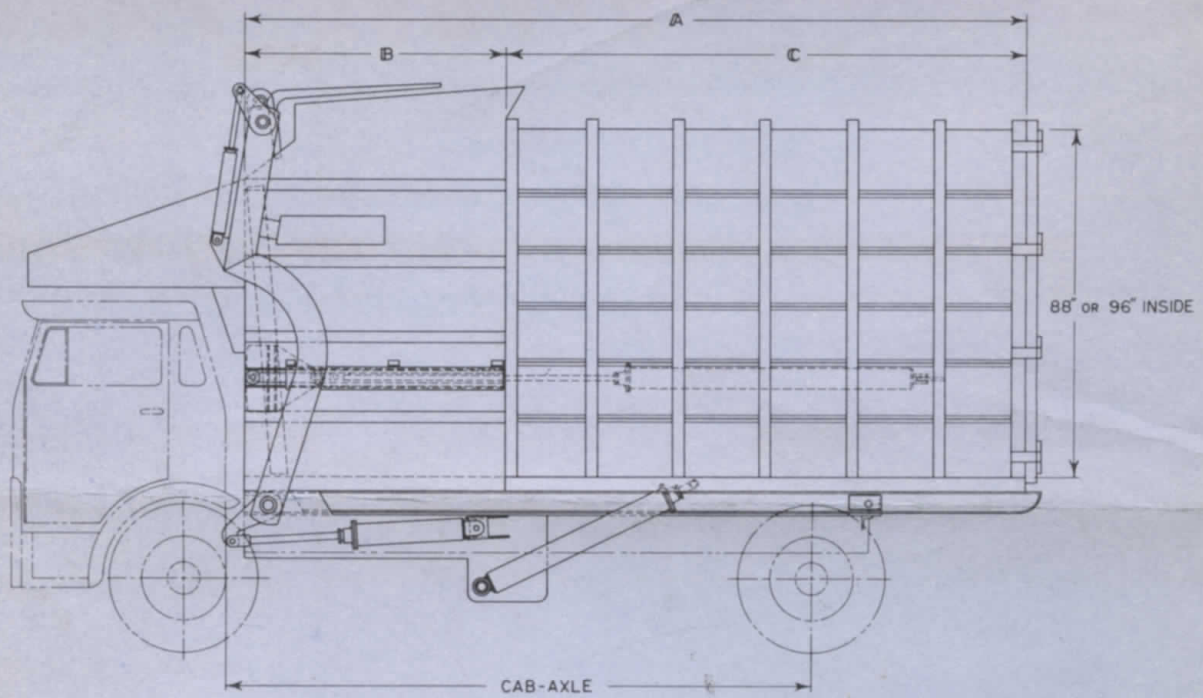

(VOLUME SHOWN IN CUBIC YARDS)

SIZE	LENGTH INSIDE			WIDTH INSIDE		VOLUME AT 88" HEIGHT			VOLUME AT 96" HEIGHT			TRUCK REQUIREMENTS (MIN.)		
	A	B	C	HOPPER	BODY	HOPPER	BODY	TOTAL	HOPPER	BODY	TOTAL	FRONT	REAR	CAB-AXLE
16 FT	16'-0"	6'-0"	10'-0"	6'-8"	7'-7"	9.8	20.6	30.4	10.8	22.4	33.2	12,000 [#]	21,000 [#]	137-140
18 FT	18'-0"	6'-0"	12'-0"	6'-8"	7'-7"	9.8	24.7	34.5	10.8	26.9	37.7	14,000 [#]	21,000 [#]	160-165

BASED ON 18" WHEELS AND 10" HUBS
 STANDARD FRONT AND REAR AXLE SPACINGS
 ON TWO AXLE CHASSIS

S. VINCENT BOWLES INC.		MODEL NO.	18-1017
FRONT LOADING PACKER		MODEL NO.	18-1017
ON TWO AXLE CHASSIS		MODEL NO.	18-1017

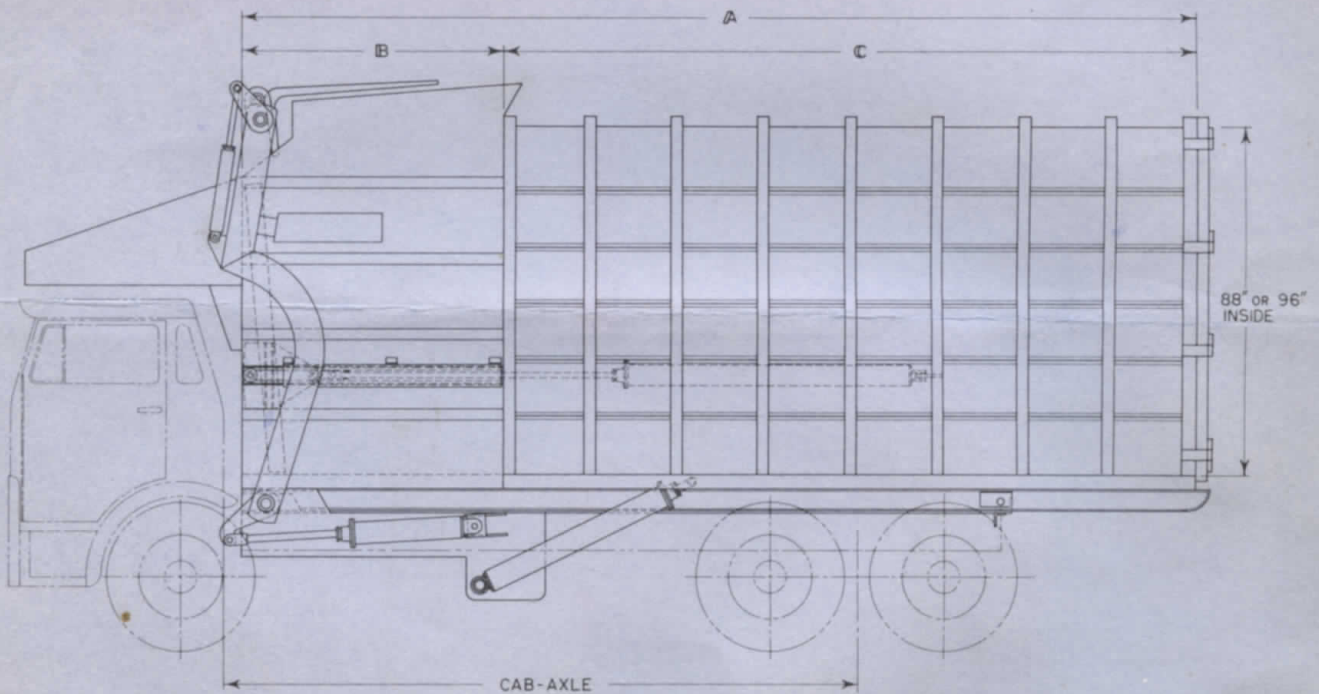

(VOLUME SHOWN IN CUBIC YARDS)

SIZE	LENGTH INSIDE			WIDTH INSIDE		VOLUME AT 88" HEIGHT			VOLUME AT 96" HEIGHT			TRUCK REQUIREMENTS (MIN.)		
	A	B	C	HOPPER	BODY	HOPPER	BODY	TOTAL	HOPPER	BODY	TOTAL	FRONT	REAR	CAB-AXLE
18 FT	18'-0"	6'-0"	12'-0"	6'-8"	7'-7"	9.8	24.7	34.5	10.8	26.9	37.7	12,000 [#]	34,000 [#]	137-140
20 FT	20'-0"	6'-0"	14'-0"	6'-8"	7'-7"	9.8	28.8	38.6	10.8	31.4	42.2	15,000 [#]	34,000 [#]	154-160
22 FT	22'-0"	6'-0"	16'-0"	6'-8"	7'-7"	9.8	32.9	42.7	10.8	35.9	46.7	15,000 [#]	34,000 [#]	170-175
23 FT	23'-0"	6'-0"	17'-0"	6'-8"	7'-7"	9.8	35.0	44.8	10.8	38.2	49.0	15,000 [#]	34,000 [#]	182-186
24 FT	24'-0"	6'-0"	18'-0"	6'-8"	7'-7"	9.8	37.0	46.8	10.8	40.4	51.2	15,000 [#]	34,000 [#]	186-191

BASED ON 18" WHEELS AND 10" HUBS
 STANDARD FRONT AND REAR AXLE SPACINGS
 ON THREE AXLE CHASSIS

S. VINCENT BOWLES INC.		MODEL NO.	22-1024
FRONT LOADING PACKER		MODEL NO.	22-1024
ON THREE AXLE CHASSIS		MODEL NO.	22-1024

CONVENIENT INSIDE CONTROLS FOR OPERATION OF LIFTING ARMS, CONTAINER FORKS, PACKING BLADE AND BODY HOIST.

PACKING BLADE S
CYLINDERS INSTAL

CAB PROTECTOR IS PROVIDED.

MECHANICAL MIRRORS ARE FURNISHED WHICH AUTOMATICALLY CHANGE POSITION TO CLEAR MOVEMENT OF LIFTING ARMS. THEY WILL BE INSTALLED ON THE TRUCK CAB, OR ON THE BODY CANOPY, AS DESIGNATED.

STANDARD EQUIPMENT FEATURES IN BLACK & BLUE
OPTIONAL EQUIPMENT FEATURES IN RED

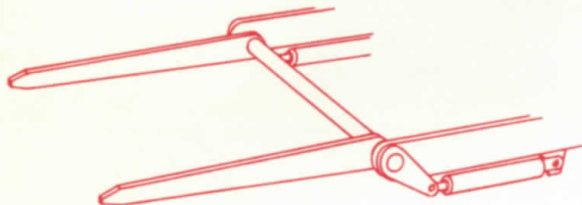

SIDE PICK UP FORKS ARE AVAILABLE IF DESIRED

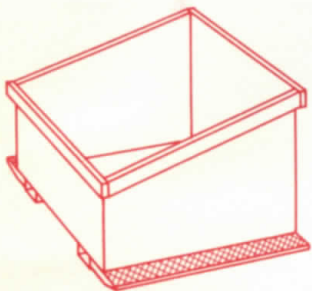

CARRY CONTAINER AVAILABLE WITH OPTIONS INCLUDING:

- RAILING OF CHANNEL, PIPE, OR MOLDED RUBBER
- STEEL OR RUBBER CASTORS, STATIONARY OR SWIVEL
- STEPS ON ENDS & SPECIFIED FORK GUIDE LOCATION

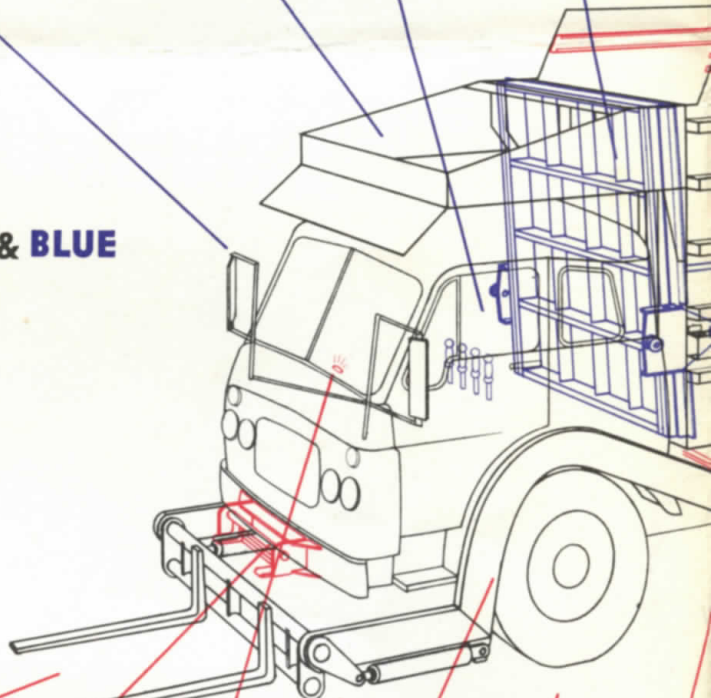

ADJUSTABLE FORK WIDTH

BUMPER STOP TO SUPPORT
ARM AND FORK ASSEMBLY

FORK WARNING LIGHT ON DASH

DOCK LOADING FEATURE

HIGHER CAPACITY ARMS AVAILABLE
ABOVE STANDARD 4000# CAPACITY

ARM AND DOOR SAFETY FEATURE PREVENTS
ARM TRAVEL WHEN DOORS ARE OPEN

OUTSIDE CONTROLS AVAILABLE AS REQUIRED

SHOWN IN THE BODY IS A PULL TYPE UNIT WITH
MOUNTED IN THE BODY SIDES. (NOTE ALTERNATE STYLE BELOW)

HYDRAULIC SYSTEM HAS DOUBLE ACTING CYLINDERS MANUFACTURED
BY S. VINCEN BOWLES, INC., USING HIGH PRESSURE HOSE ON PRESSURE
SIDE OF SYSTEM AND EXTRA HEAVY PIPE.

PAINTED CUSTOMERS CHOICE OF COLOR

ALL LEGAL BODY EQUIPMENT IS PROVIDED.

REAR DOORS ARE BARN DOOR TYPE, EACH
WITH FOUR HINGES, PROVIDING FULL BODY
OPENING. LATCHES ARE CAM AND LEVER
TYPE AT BOTH TOP AND BOTTOM.

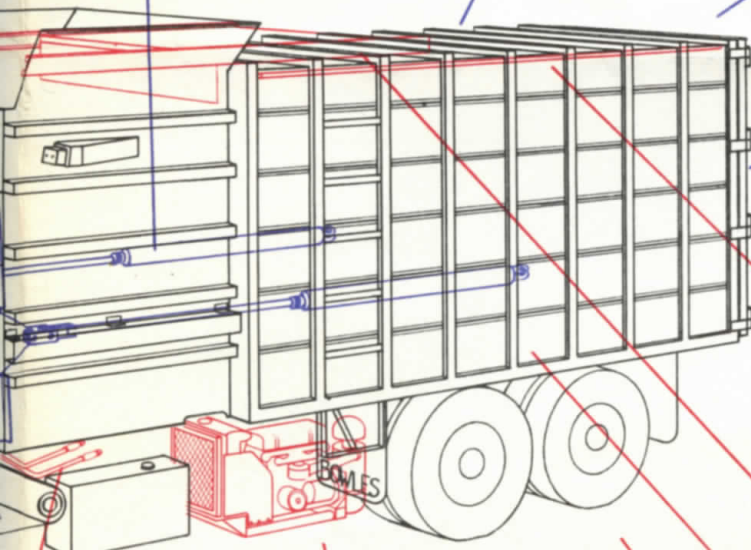

SPRINKLER SYSTEMS FOR GREATER COMPACTION.

SINGLE CYCLE PACKING FEATURE

HOPPER COVER ON TOP IS AVAILABLE WITH
HYDRAULIC OR CHAIN OPERATED CONTROL.

HIGH TENSILE STEEL IS OPTIONAL

BODY SIZE AND CAPACITY AS REQUIRED.

PACKING BLADE AVAILABLE WITH PARTIAL OR FULL TRAVEL
THROUGH BODY.

CLEAN OUT DOORS ARE AVAILABLE IF DESIRED.

PITCH IN DOORS MAY BE INSTALLED.

FEATURE AVAILABLE TO PREVENT DUMPING BEHIND PACKING BLADE.

AUXILIARY ENGINES ELIMINATE EXCESSIVE TRANSMISSION LOADS AND WEAR
PLUS PROVIDING HYDRAULIC PRESSURE FOR CONTROLS WHEN IN TRANSIT.

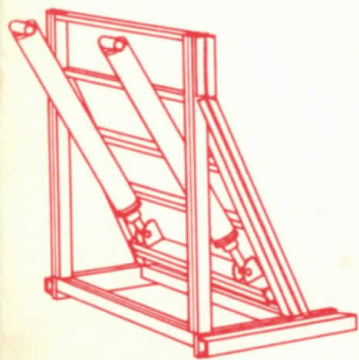

PUSH TYPE PACKING BLADE

OPERATION



FRONT LOADER ASSEMBLY

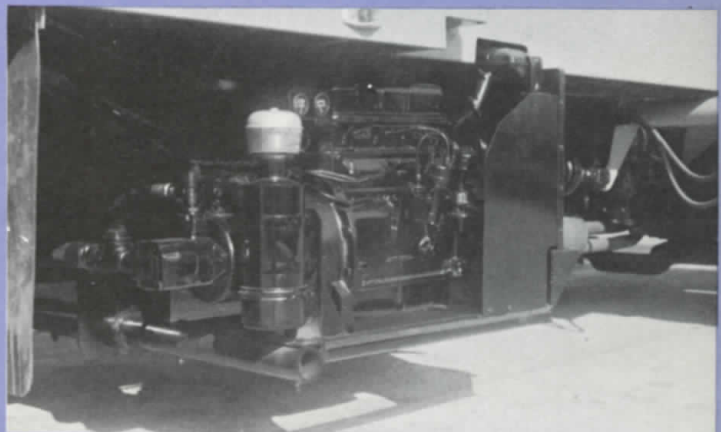

AUXILIARY ENGINE

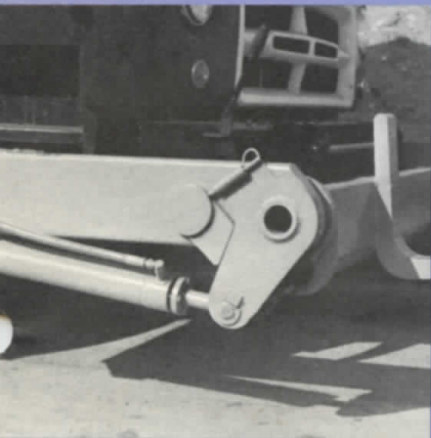

DOCK LOADER

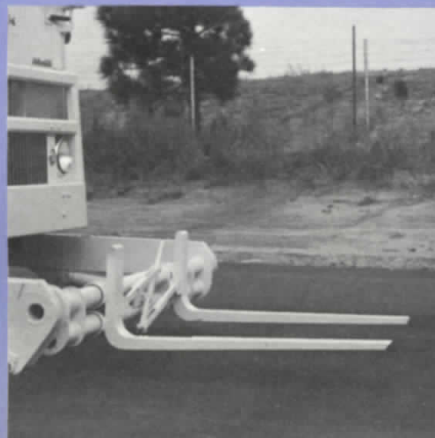

SLIDING FORKS



REAR DOORS

CONTAINERS

FOR

INDUSTRIAL PLANTS

RETAIL STORES

APARTMENT HOUSES

WAREHOUSES

FOOD HANDLERS

INSTITUTIONS

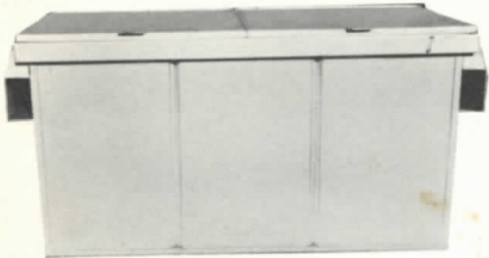

SPECIFICATIONS

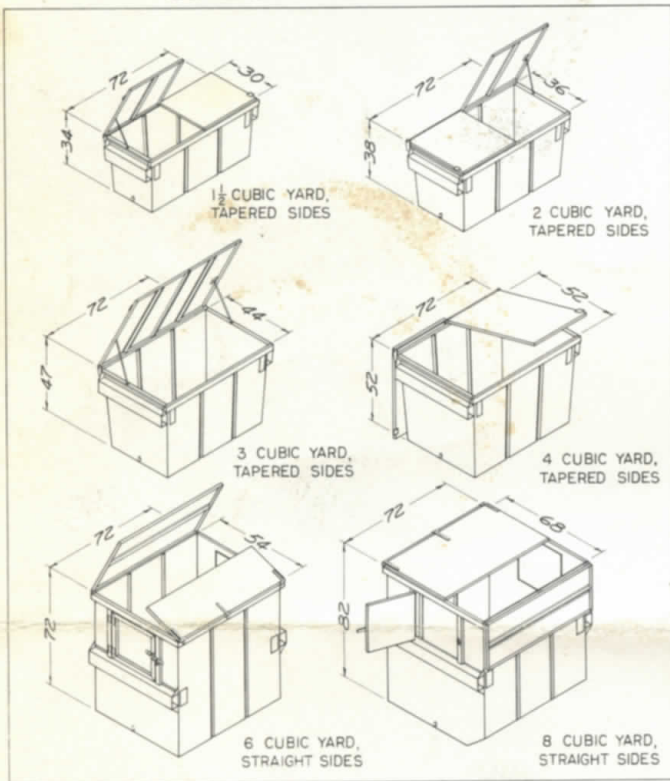

TAPERED UNITS NEST FOR SHIPMENT

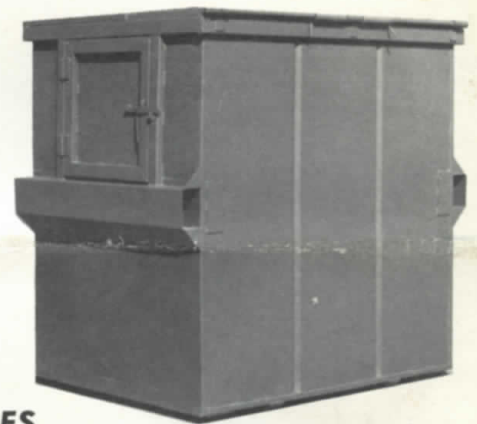

STANDARD AND OPTIONAL FEATURES

TAPERED SIDES, 1 1/2 TO 4 YD. SIZE
 PITCH IN SIDE DOORS, 6 AND 8 YD. SIZE
 FORK GUIDES FOR SIDE OR BOTTOM PICKUP
 REINFORCED RIGID DOORS
 DOUBLE TOP DOORS
 CORRUGATED SIDE PANELS

CASTOR PADS AND SKIDS
 DRAIN PLUG
 HEAVY GAUGE STEEL
 PRIMED AND PAINTED CHOICE OF COLOR
 CASTORS AVAILABLE
 SPRING LOADED DOORS AVAILABLE

S. VINCEN BOWLES, INC.

12039 Branford St., Sun Valley, California
 Phone 899-9511 Area Code 213