

# Base Model Specifications

## INTEGRATED FRONT LOADER



Illustration representative of model, but not necessarily of these specifications.

## 44 CU. YD. TANDEM AXLE

### MODEL IFL44-T

Complete refuse vehicle...built by one manufacturer.  
An innovative concept...using proven components.

### GENERAL DATA

#### ■ DIMENSIONS

WHEELBASE, ins.	208
WEIGHT, est. lbs.	32,400
LENGTH, overall, ft.-ins.	32-4
HEIGHT, ft.-ins.	12-6
WIDTH, overall, ins.	96

#### ■ BODY

CONTAINER LIFT, cap., lbs.	8,000
TOTAL VOLUME, CU. YDS.	44
• Body Volume, cu. yds.	32
• Hopper Volume, cu. yds.	12
BODY SHAPE	Cylindrical
BODY WELDING	Full
CONSTRUCTION MATERIAL, Steel	
Hopper	
• Floor, in., psi	3/16 - 100,000
• Sides, in., psi	3/16 - 80,000
Body	
• Floor, in., psi	3/16 - 100,000
• Sides and Roof, ga., psi	10 - 80,000
PACKING/EJECTION SYSTEM	Full Sweep
CLEAN OUT HATCH	Left front of body

#### ■ CYLINDERS

Double acting, chrome-plated rods	All
PACKING, 5 stage, dia., ins.	8.5 *
T.G. RAISE, dia., ins.	3
LIFT, dia., ins.	4
DUMP, dia., ins.	3

#### ■ TAILGATE

LIFT	Hydraulic
LATCH	Manual
CONSTRUCTION, steel, ga., psi	10 - 80,000

#### ■ HYDRAULIC SYSTEM

PUMP, Type	Gear with dry valve
• Size, gpm @ 1000 rpm	34
P.T.O.	Crankshaft drive
SYSTEM PRESSURE, psi	2,500
PACKING PRESSURE, psi	2,000
RESERVOIR, gals.	60

#### ■ POWER SYSTEM

ENGINE	CUMMINS L-10 *
• Horsepower	260
• Governed Speed, r.p.m.	1950
• Lube Oil Filter	Full flow
TRANSMISSION	ALLISON HT740RS *
• 4 speeds forward, 1 reverse	
• Filter, Spin on	Remote
• Oil Cooler	Water to oil
PROPELLER SHAFTS	1710 HD
RADIATOR, Remote, 3 Row Serpentine Core, sq. ins.	1200
AIR CLEANER	intake above cab, 14" Donaldson
EXHAUST	Horizontal
FUEL TANK integral, gal.	76

#### ■ AXLES, SUSPENSION

FRONT AXLE, Eaton EFA-20F4, cap., lbs.	20,000
FRONT SUSPENSION, CCC, cap., lbs.	40,000
REAR AXLE, Eaton DS40Z, cap., lbs.	40,000 *
• Ratio	4.56:1
REAR SUSPENSION, HendricksonRS400, lbs.	26,000 *
WHEELS, front and rear	20" Cast Spoke
Tag	15" Cast Spoke
RIMS, front, ins.	20 x 10
rear, ins.	20 x 8
TIRES, front, Goodyear	14/80R20
rear, Goodyear	10.00X20
tag, Goodyear	8.25 x 15

#### ■ BRAKES

FRONT, S-CAM, ins.	16.5 x 6
REAR, S-CAM, ins.	16.5 x 7
RESERVOIR, cap., cu. ins.	7,000
AIR COMPRESSOR, Cummins, C.F.M.	13.2
PARKING, rear axles	Spring loaded

#### ■ STEERING

DRIVERS STATION	Left Side
TYPE, Sheppard	Integral gear S592
• Cap., lbs.	20,000
• Turning radius, wall to wall, (approx.) ft.	36

#### ■ ELECTRICAL

SYSTEM TYPE	12 V. Negative Ground
ALTERNATOR, Delco, 27 SI, amps	80
BATTERIES, maintenance free, 12 volt	3
• Total cold cranking amps, CCA	2,250

Specifications subject to change without notice.

\* Optional components available.

# CCC

THE REFUSE VEHICLE SPECIALISTS

IFL 2/91

## STANDARD EQUIPMENT

### CAB

LOW ENTRY FIXED CAB  
ALL WELDED ALUMINUM  
ALL TINTED FLAT SAFETY GLASS  
AIR OPERATED WINDSHIELD WIPERS WITH WASHERS  
BENCH TYPE DRIVER'S AND PASSENGER'S SEAT  
RETRACTABLE SEAT BELTS  
L.H. AND R.H. SUNVISORS  
FRESH AIR HEATER WITH RECIRCULATING HEATER AND DEFROSTER

DUAL STAINLESS REAR VIEW MIRRORS  
16" X 6" WITH 8.5" R.H. CONVEX SPOT  
and 8.5" CONVEX DUMPING MIRROR  
ROLL DOWN WINDOWS  
ELECTRICAL SPEEDOMETER  
ELECTRICAL TACHOMETER W/ HOURMETER  
DUAL AIR PRESSURE GAUGE  
MODULE PANEL W/REPLACEABLE GAUGES  
VOLTMETER, ELECTRICAL OIL PRESSURE  
WATER TEMPERATURE AND FUEL

### BODY

CRANKSHAFT MOUNTED DRY VALVE PUMP  
RETURN LINE FILTER - REPLACEABLE ELEMENT  
HOLDING VALVE IN TAILGATE CYLINDERS  
HYDRAULIC SIGHT GAUGE  
FULL FOLDING FORKS

O-RING SEAL HYDRAULIC FITTINGS  
CHROME PLATED CYLINDER RODS  
CAB LADDER  
SILICONE-FILLED CONTROL CABLES

### ELECTRICAL

MANUAL RESET CIRCUIT BREAKERS  
COLOR CODED WIRING  
EXTERIOR BODY WIRING INSTALLED IN  
CONDUIT W/WATERPROOF JUNCTION BOXES  
P.T.O. "ON" INDICATOR LIGHT  
SINGLE HEADLIGHTS  
FRONT AND REAR TURN SIGNALS  
IDENTIFICATION AND CLEARANCE LIGHTS  
SHOCK MOUNTED TAIL AND CLEARANCE LIGHTS  
DOME LIGHT IN CAB  
HAZARD WARNING FLASHER  
SINGLE ELECTRICAL HORN

WARNING LIGHT AND BUZZER FOR:  
• LOW AIR AND OIL PRESSURE  
• HIGH WATER TEMPERATURE  
INDICATOR LIGHT FOR:  
• PARKING BRAKE  
• TRANSMISSION HIGH TEMPERATURE  
• TRANSMISSION NEUTRAL  
• INTERAXLE DIFFERENTIAL  
30 AMP RADIO CIRCUIT  
SPARE SWITCH - DASH MOUNTED IN CAB  
BACK-UP ALARM  
BACK-UP LIGHT IN REAR CLUSTER

### PAINT

WHITE, POLYURETHANE ENAMEL:  
CAB, BODY, BUMPER, FENDERS, WHEELS, AIR  
CLEANER AND BACK OF PACKER PANEL

### MISCELLANEOUS

LATERAL TORQUE RODS  
WHEEL OIL SEALS - ALL AXLES  
MUD FLAPS FRONT AND REAR OF TANDEM AND REAR OF  
FRONT WHEELS  
GATE TYPE TRANSMISSION SHIFT CONTROL  
WILLIAMS AIR THROTTLE CONTROL  
AIR RESTRICTION INDICATOR - AIR CLEANER MOUNTED  
TOW LOOPS, FRONT AND REAR  
ICC BUMPER

## OPTIONAL COMPONENTS

### ENGINE

(VARIOUS HORSE POWER)  
CUMMINS - 6CTB.3, L-10  
CAT- 3116, 3306  
DETROIT - 6L-71TA DDEC

### TRANSMISSION

MANUAL, CONSULT FACTORY  
AUTOMATIC ALLISON MT653,  
MT654, HT754

### WHEEL

DISC, STEEL, FRONT AND REAR  
DISC, ALUMINUM, REAR

### REAR SUSPENSION

HENDRICKSON RS460, 46,000#  
RIDEWELL 48K, 48,000#

### REAR AXLE

EATON DS451p, 45,000#  
EATON DS461p, 46,000#  
ROCKWELL RT-40-145, 40,000#  
ROCKWELL RT-46-160, 46,000#

### TIRE

FRONT, 315/80R22.5, 385/65R22.5, 425/65R22.5  
REAR, VARIOUS, TUBE AND TUBELESS

### CAB

AIR CONDITIONING  
DRIVER SEAT AIR RIDE OR T BAR  
AIR HORN  
FAN, DASH MOUNTED  
FIRE EXTINGUISHER

### MISCELLANEOUS

BLOCK HEATER  
ETHER START AID  
FUEL/WATER SEPARATOR  
TRANSMISSION OIL COOLER  
AIR DRYER

### BODY

AIR OVER HYDRAULIC CONTROLS  
HIGH COMPACTION PACKER CYLINDER (10" DIA.)  
HYDRAULIC TAILGATE LATCHES  
CONTAINER OPERATION FLOODLIGHT  
HOPPER FLOODLIGHT  
BACK UP FLOODLIGHT  
PACKER BLADE INTERLOCK  
TAILGATE STROBE LIGHT  
WASHOUT TANK  
DUPLICATE STOP AND TURN SIGNALS

AIR DRAIN VALVE, AUTOMATIC  
SLACK ADJUSTERS, BRAKE, AUTOMATIC  
ALCOHOL INJECTOR  
HAND CONTROL VALVE, BRAKE  
BATTERY (IES), ADDITIONAL  
BATTERY DISCONNECT SWITCH

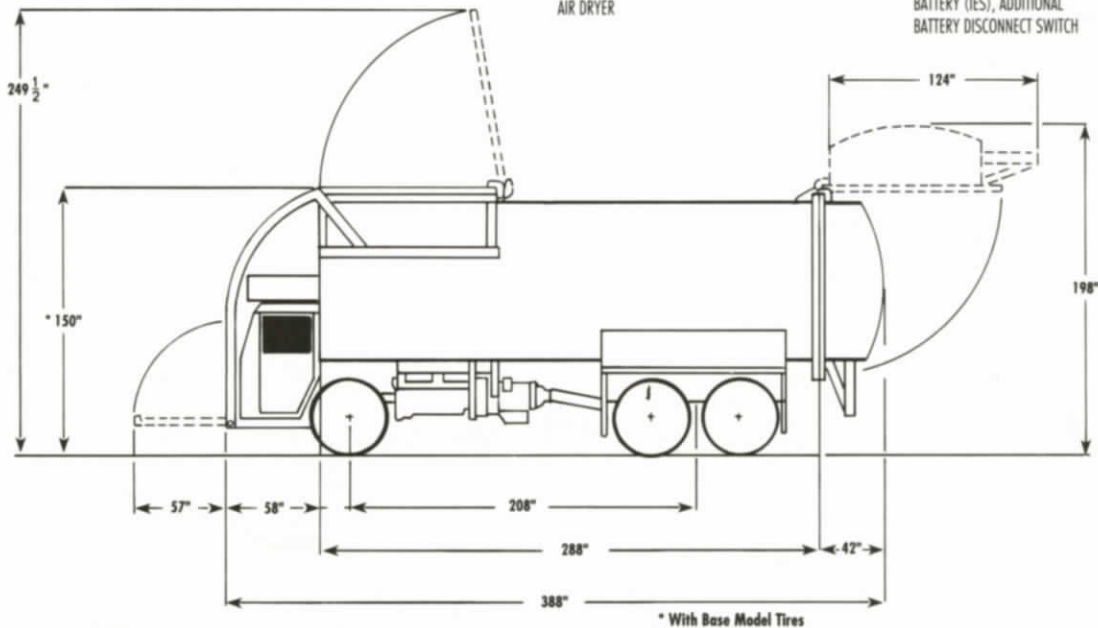

Specifications subject to change without notice.



CRANE CARRIER COMPANY, P.O. BOX 582891, TULSA, OK. 74158 (918) 836-1651

# Base Model Specifications

## INTEGRATED FRONT LOADER



Illustration representative of model, but not necessarily of these specifications.

## 44 CU. YD. TANDEM AXLE WITH PUSHER LIFT AXLE

### MODEL IFL44TP

Complete refuse vehicle...built by one manufacturer.  
An innovative concept...using proven components.

### GENERAL DATA

#### ■ DIMENSIONS

WHEELBASE, ins.	208
WEIGHT, est. lbs.	34,300
LENGTH, overall, ft.-ins.	32-4
HEIGHT, ft.-ins.	12-6
WIDTH, overall, ins.	96

#### ■ BODY

CONTAINER LIFT, cap., lbs.	8,000
TOTAL VOLUME, CU. YDS.	44
• Body Volume, cu. yds.	32
• Hopper Volume, cu. yds.	12
BODY SHAPE	Cylindrical
BODY WELDING	Full
CONSTRUCTION MATERIAL, Steel	

Hopper	
• Floor, in., psi	3/16 - 100,000
• Sides, in., psi	3/16 - 80,000
Body	
• Floor, in., psi	3/16 - 100,000
• Sides and Roof, ga., psi	10 - 80,000
PACKING/EJECTION SYSTEM	Full Sweep
CLEAN OUT HATCH	Left front of body

#### ■ CYLINDERS

Double acting, chrome-plated rods	All
PACKING, 5 stage, dia., ins.	8.5 *
T.G. RAISE, dia., ins.	3
LIFT, dia., ins.	4
DUMP, dia., ins.	3

#### ■ TAILGATE

LIFT	Hydraulic
LATCH	Manual
CONSTRUCTION, steel, ga., psi	10 - 80,000

#### ■ HYDRAULIC SYSTEM

PUMP, Type	Gear with dry valve
• Size, gpm @ 1000 rpm	34
P.T.O.	Crankshaft drive
SYSTEM PRESSURE, psi	2,500
PACKING PRESSURE, psi	2,000
RESERVOIR, gals.	60

#### ■ POWER SYSTEM

ENGINE	CUMMINS L-10 *
• Horsepower	260
• Governed Speed, r.p.m.	1950
• Lube Oil Filter	Full Flow
TRANSMISSION	ALLISON HT740RS *
• 4 speeds forward, 1 reverse	
• Filter, Spin on	Remote
• Oil Cooler	Water to oil
PROPELLER SHAFTS	1710 HD
RADIATOR, Remote, 3 Row Serpentine Core, sq. ins.	1200
AIR CLEANER	intake above cab, 14" Donaldson
EXHAUST	Horizontal
FUEL TANK integral, gal.	76

#### ■ AXLES, SUSPENSION

FRONT AXLE, Eaton EFA-20F4, cap., lbs.	20,000
FRONT SUSPENSION, CCC, cap., lbs.	40,000
REAR AXLE, Eaton DS402, cap., lbs.	40,000 *
• Ratio	4.56:1
REAR SUSPENSION, HendricksonRS400, lbs.	26,000 *
WHEELS, front and rear	20" Cast Spoke
Tag	15" Cast Spoke
RIMS, front, ins.	20 x 10
rear, ins.	20 x 8
TIRES, front, Goodyear	14/80R20
rear, Goodyear	10.00X20
tag, Goodyear	8.25 x 15

#### ■ BRAKES

FRONT, S-CAM, ins.	16.5 x 6
REAR, S-CAM, ins.	16.5 x 7
RESERVOIR, cap., cu. ins.	7,000
AIR COMPRESSOR, Cummins, C.F.M.	13.2
PARKING, rear axles	Spring loaded

#### ■ STEERING

DRIVERS STATION	Left Side
TYPE, Sheppard	Integral gear SS92
• Cap., lbs.	20,000
• Turning radius, wall to wall, (approx.) ft.	36

#### ■ ELECTRICAL

SYSTEM TYPE	12 V. Negative Ground
ALTERNATOR, Delco, 27 SI, amps	80
BATTERIES, maintenance free, 12 volt	3
• Total cold cranking amps, CCA	2,250

Specifications subject to change without notice.

\* Optional components available.



THE REFUSE VEHICLE SPECIALISTS

## STANDARD EQUIPMENT

### CAB

LOW ENTRY FIXED CAB  
ALL WELDED ALUMINUM  
ALL TINTED FLAT SAFETY GLASS  
AIR OPERATED WINDSHIELD WIPERS WITH WASHERS  
BENCH TYPE DRIVER'S AND PASSENGER'S SEAT  
RETRACTABLE SEAT BELTS  
L.H. AND R.H. SUNVISORS  
FRESH AIR HEATER WITH RECIRCULATING HEATER AND DEFROSTER

DUAL STAINLESS REAR VIEW MIRRORS  
16" X 6" WITH 8.5" R.H. CONVEX SPOT  
and 8.5" CONVEX DUMPING MIRROR  
ROLL DOWN WINDOWS  
ELECTRICAL SPEEDOMETER  
ELECTRICAL TACHOMETER W/ HOURMETER  
DUAL AIR PRESSURE GAUGE  
MODULE PANEL W/REPLACEABLE GAUGES  
VOLTMETER, ELECTRICAL OIL PRESSURE  
WATER TEMPERATURE AND FUEL

### ELECTRICAL

MANUAL RESET CIRCUIT BREAKERS  
COLOR CODED WIRING  
EXTERIOR BODY WIRING INSTALLED IN  
CONDUIT W/WATERPROOF JUNCTION BOXES  
P.T.O. "ON" INDICATOR LIGHT  
SINGLE HEADLIGHTS  
FRONT AND REAR TURN SIGNALS  
IDENTIFICATION AND CLEARANCE LIGHTS  
SHOCK MOUNTED TAIL AND CLEARANCE LIGHTS  
DOME LIGHT IN CAB  
HAZARD WARNING FLASHER  
SINGLE ELECTRICAL HORN

WARNING LIGHT AND BUZZER FOR:  
• LOW AIR AND OIL PRESSURE  
• HIGH WATER TEMPERATURE  
INDICATOR LIGHT FOR:  
• PARKING BRAKE  
• TRANSMISSION HIGH TEMPERATURE  
• TRANSMISSION NEUTRAL  
• INTERAXLE DIFFERENTIAL  
30 AMP RADIO CIRCUIT  
SPARE SWITCH - DASH MOUNTED IN CAB  
BACK-UP ALARM  
BACK-UP LIGHT IN REAR CLUSTER

### BODY

CRANKSHAFT MOUNTED DRY VALVE PUMP  
RETURN LINE FILTER - REPLACEABLE ELEMENT  
HOLDING VALVE IN TAILGATE CYLINDERS  
HYDRAULIC SIGHT GAUGE  
FULL FOLDING FORKS

O-RING SEAL HYDRAULIC FITTINGS  
CHROME PLATED CYLINDER RODS  
CAB LADDER  
SILICONE-FILLED CONTROL CABLES

### PAINT

WHITE, POLYURETHANE ENAMEL:  
CAB, BODY, BUMPER, FENDERS, WHEELS, AIR  
CLEANER AND BACK OF PACKER PANEL

### MISCELLANEOUS

LATERAL TORQUE RODS  
WHEEL OIL SEALS - ALL AXLES  
MUD FLAPS FRONT AND REAR OF TANDEM AND REAR OF  
FRONT WHEELS  
GATE TYPE TRANSMISSION SHIFT CONTROL  
WILLIAMS AIR THROTTLE CONTROL  
AIR RESTRICTION INDICATOR - AIR CLEANER MOUNTED  
TOW LOOPS, FRONT AND REAR  
ICC BUMPER

## OPTIONAL COMPONENTS

### ENGINE

(VARIOUS HORSE POWER)  
CUMMINS - 6CT8.3, L-10  
CAT - 3116, 3306  
DETROIT - 6L-71TA DDEC

### TRANSMISSION

MANUAL, CONSULT FACTORY  
AUTOMATIC ALLISON MT653,  
MT654, HT754

### WHEEL

DISC, STEEL, FRONT AND REAR  
DISC, ALUMINUM, REAR

### REAR SUSPENSION

HENDRICKSON RS460, 46,000#  
RIDEWELL 48K, 48,000#

### REAR AXLE

EATON DS451p, 45,000#  
EATON DS461p, 46,000#  
ROCKWELL RT-40-145, 40,000#  
ROCKWELL RT-46-160, 40,000#

### TIRE

FRONT, 315/80R22.5, 385/65R22.5, 425/65R22.5  
REAR, VARIOUS, TUBE AND TUBELESS

### CAB

AIR CONDITIONING  
DRIVER SEAT AIR RIDE OR T BAR  
AIR HORN  
FAN, DASH MOUNTED  
FIRE EXTINGUISHER

### MISCELLANEOUS

BLOCK HEATER  
ETHER START AID  
FUEL/WATER SEPARATOR  
TRANSMISSION OIL COOLER  
AIR DRYER

### BODY

AIR OVER HYDRAULIC CONTROLS  
HIGH COMPACTION PACKER CYLINDER (10" DIA.)  
HYDRAULIC TAILGATE LATCHES  
CONTAINER OPERATION FLOODLIGHT  
HOPPER FLOODLIGHT  
BACK UP FLOODLIGHT  
PACKER BLADE INTERLOCK  
TAILGATE STROBE LIGHT  
WASHOUT TANK  
DUPLICATE STOP AND TURN SIGNALS

AIR DRAIN VALVE, AUTOMATIC  
SLACK ADJUSTERS, BRAKE, AUTOMATIC  
ALCOHOL INJECTOR  
HAND CONTROL VALVE, BRAKE  
BATTERY (IES), ADDITIONAL  
BATTERY DISCONNECT SWITCH

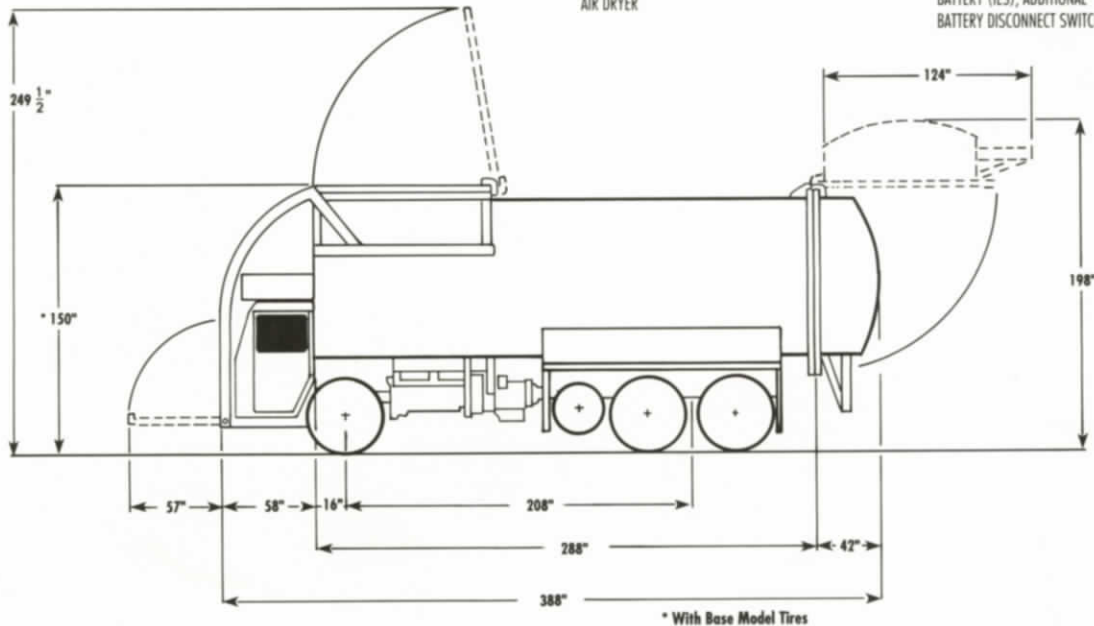

Specifications subject to change without notice.

**CCC**

CRANE CARRIER COMPANY, P.O. BOX 582891, TULSA, OK. 74158 (918) 836-1651

# Base Model Specifications

## INTEGRATED FRONT LOADER



Illustration representative of model, but not necessarily of these specifications.

## 49 CU. YD. TANDEM AXLE WITH TAG LIFT AXLE

### MODEL IFL49TT

Complete refuse vehicle...built by one manufacturer.  
An innovative concept...using proven components.

### GENERAL DATA

#### ■ DIMENSIONS

WHEELBASE, ins.	192
WEIGHT, est. lbs.	34,800
LENGTH, overall, ft.-ins.	35-0
HEIGHT, ft.-ins.	12-6
WIDTH, overall, ins.	96

#### ■ BODY

CONTAINER LIFT, cap., lbs.	8,000
TOTAL VOLUME, CU. YDS.	49
• Body Volume, cu. yds.	37
• Hopper Volume, cu. yds.	12
BODY SHAPE	Cylindrical
BODY WELDING	Full
CONSTRUCTION MATERIAL, Steel	
Hopper	
• Floor, in., psi	3/16 - 100,000
• Sides, in., psi	3/16 - 80,000
Body	
• Floor, in., psi	3/16 - 100,000
• Sides and Roof, ga., psi	10 - 80,000
PACKING/EJECTION SYSTEM	Full Sweep
CLEAN OUT HATCH	Left front of body

#### ■ CYLINDERS

Double acting, chrome-plated rods	All
PACKING, 6 stage, dia., ins.	10
T.G. RAISE, dia., ins.	3
LIFT, dia., ins.	4
DUMP, dia., ins.	3

#### ■ TAILGATE

LIFT	Hydraulic
LATCH	Manual
CONSTRUCTION, steel, ga., psi	10 - 80,000

#### ■ HYDRAULIC SYSTEM

PUMP, Type	Gear with dry valve
• Size, gpm @ 1000 rpm	34
P.T.O.	Crankshaft drive
SYSTEM PRESSURE, psi	2,500
PACKING PRESSURE, psi	2,000
RESERVOIR, gals.	60

#### ■ POWER SYSTEM

ENGINE	CUMMINS L-10*
• Horsepower	260
• Governed Speed, r.p.m.	1950
• Lube Oil Filter	Full flow
TRANSMISSION	ALLISON HT740RS*
• 4 speeds forward, 1 reverse	
• Filter, Spin on	Remote
• Oil Cooler	Water to oil
PROPELLER SHAFTS	1710 HD
RADIATOR, Remote, 3 Row Serpentine Core, sq. ins.	1200
AIR CLEANER	intake above cab, 14" Donaldson
EXHAUST	Horizontal
FUEL TANK integral, gal.	76

#### ■ AXLES, SUSPENSION

FRONT AXLE, Eaton EFA-20F4, cap., lbs.	20,000
FRONT SUSPENSION, CCC, cap., lbs.	40,000
REAR AXLE, Eaton DS402, cap., lbs.	40,000*
• Ratio	4.56:1
REAR SUSPENSION, HendricksonRS400, lbs.	26,000
WHEELS, front and rear	20" Cast Spoke
Tag	15" Cast Spoke
RIMS, front, ins.	20 x 10
rear, ins.	20 x 8
TIRES, front, Goodyear	14/BOR20
rear, Goodyear	10.00X20
tag, Goodyear	8.25 x 15

#### ■ BRAKES

FRONT, S-CAM, ins.	16.5 x 6
REAR, S-CAM, ins.	16.5 x 7
RESERVOIR, cap., cu. ins.	7,000
AIR COMPRESSOR, Cummins, C.F.M.	13.2
PARKING, rear axles	Spring loaded

#### ■ STEERING

DRIVERS STATION	Left Side
TYPE, Sheppard	Integral gear S592
• Cap., lbs.	20,000
• Turning radius, wall to wall, (approx.) ft.	35

#### ■ ELECTRICAL

SYSTEM TYPE	12 V. Negative Ground
ALTERNATOR, Delco, 27 SI, amps	80
BATTERIES, maintenance free, 12 volt	3
• Total cold cranking amps, CCA	2,250

Specifications subject to change without notice.

\* Optional components available.



THE REFUSE VEHICLE SPECIALISTS

## STANDARD EQUIPMENT

### CAB

LOW ENTRY FIXED CAB  
ALL WELDED ALUMINUM  
ALL TINTED FLAT SAFETY GLASS  
AIR OPERATED WINDSHIELD WIPERS WITH WASHERS  
BENCH TYPE DRIVER'S AND PASSENGER'S SEAT  
RETRACTABLE SEAT BELTS  
L.H. AND R.H. SUNVISORS  
FRESH AIR HEATER WITH RECIRCULATING HEATER AND DEFROSTER

DUAL STAINLESS REAR VIEW MIRRORS  
16" X 6" WITH 8.5" R.H. CONVEX SPOT  
and 8.5" CONVEX DUMPING MIRROR  
ROLL DOWN WINDOWS  
ELECTRICAL SPEEDOMETER  
ELECTRICAL TACHOMETER W/ HOURMETER  
DUAL AIR PRESSURE GAUGE  
MODULE PANEL W/REPLACEABLE GAUGES  
VOLTMETER, ELECTRICAL OIL PRESSURE  
WATER TEMPERATURE AND FUEL

### ELECTRICAL

MANUAL RESET CIRCUIT BREAKERS  
COLOR CODED WIRING  
EXTERIOR BODY WIRING INSTALLED IN  
CONDUIT W/WATERPROOF JUNCTION BOXES  
P.T.O. "ON" INDICATOR LIGHT  
SINGLE HEADLIGHTS  
FRONT AND REAR TURN SIGNALS  
IDENTIFICATION AND CLEARANCE LIGHTS  
SHOCK MOUNTED TAIL AND CLEARANCE LIGHTS  
DOME LIGHT IN CAB  
HAZARD WARNING FLASHER  
SINGLE ELECTRICAL HORN

WARNING LIGHT AND BUZZER FOR:

- LOW AIR AND OIL PRESSURE
  - HIGH WATER TEMPERATURE
- INDICATOR LIGHT FOR:
- PARKING BRAKE
  - TRANSMISSION HIGH TEMPERATURE
  - TRANSMISSION NEUTRAL
  - INTERAXLE DIFFERENTIAL

30 AMP RADIO CIRCUIT  
SPARE SWITCH - DASH MOUNTED IN CAB -  
BACK-UP ALARM  
BACK-UP LIGHT IN REAR CLUSTER

### BODY

CRANKSHAFT MOUNTED DRY VALVE PUMP  
RETURN LINE FILTER - REPLACEABLE ELEMENT  
HOLDING VALVE IN TAILGATE CYLINDERS  
HYDRAULIC SIGHT GAUGE  
FULL FOLDING FORKS

O-RING SEAL HYDRAULIC FITTINGS  
CHROME PLATED CYLINDER RODS  
CAB LADDER  
SILICONE-FILLED CONTROL CABLES

### PAINT

WHITE, POLYURETHANE ENAMEL:  
CAB, BODY, BUMPER, FENDERS, WHEELS, AIR  
CLEANER AND BACK OF PACKER PANEL

### MISCELLANEOUS

LATERAL TORQUE RODS  
WHEEL OIL SEALS - ALL AXLES  
MUD FLAPS FRONT AND REAR OF TANDEM AND REAR OF  
FRONT WHEELS  
GATE TYPE TRANSMISSION SHIFT CONTROL  
WILLIAMS AIR THROTTLE CONTROL  
AIR RESTRICTION INDICATOR - AIR CLEANER MOUNTED  
TOW LOOPS, FRONT AND REAR  
ICC BUMPER

## OPTIONAL COMPONENTS

### ENGINE

(VARIOUS HORSE POWER)  
CUMMINS - 6CT8.3, I-10  
CAT-3116, 3306  
DETROIT - 6L-71TA DDEC

### TRANSMISSION

MANUAL, CONSULT FACTORY  
AUTOMATIC ALLISON MT653,  
MT654, HT754

### WHEEL

DISC, STEEL, FRONT AND REAR  
DISC, ALUMINUM, REAR

### REAR SUSPENSION

HENDRICKSON RS460, 46,000#  
RIDEWELL 48K, 48,000#

### REAR AXLE

EATON DS451p, 45,000#  
EATON DS461p, 46,000#  
ROCKWELL RT-40-145, 46,000#  
ROCKWELL RT-46-160, 40,000#

### TIRE

FRONT, 315/80R22.5, 385/65R22.5, 425/65R22.5  
REAR, VARIOUS, TUBE AND TUBELESS

### CAB

AIR CONDITIONING  
DRIVER SEAT AIR RIDE OR T BAR  
AIR HORN  
FAN, DASH MOUNTED  
FIRE EXTINGUISHER

### MISCELLANEOUS

BLOCK HEATER  
ETHER START AID  
FUEL/WATER SEPARATOR  
TRANSMISSION OIL COOLER  
AIR DRYER

### BODY

AIR OVER HYDRAULIC CONTROLS  
HIGH COMPACTION PACKER CYLINDER (10" DIA.)  
HYDRAULIC TAILGATE LATCHES  
CONTAINER OPERATION FLOODLIGHT  
HOPPER FLOODLIGHT  
BACK UP FLOODLIGHT  
PACKER BLADE INTERLOCK  
TAILGATE STROBE LIGHT  
WASHOUT TANK  
DUPLICATE STOP AND TURN SIGNALS

AIR DRAIN VALVE, AUTOMATIC  
SLACK ADJUSTERS, BRAKE, AUTOMATIC  
ALCOHOL INJECTOR  
HAND CONTROL VALVE, BRAKE  
BATTERY (IES), ADDITIONAL  
BATTERY DISCONNECT SWITCH

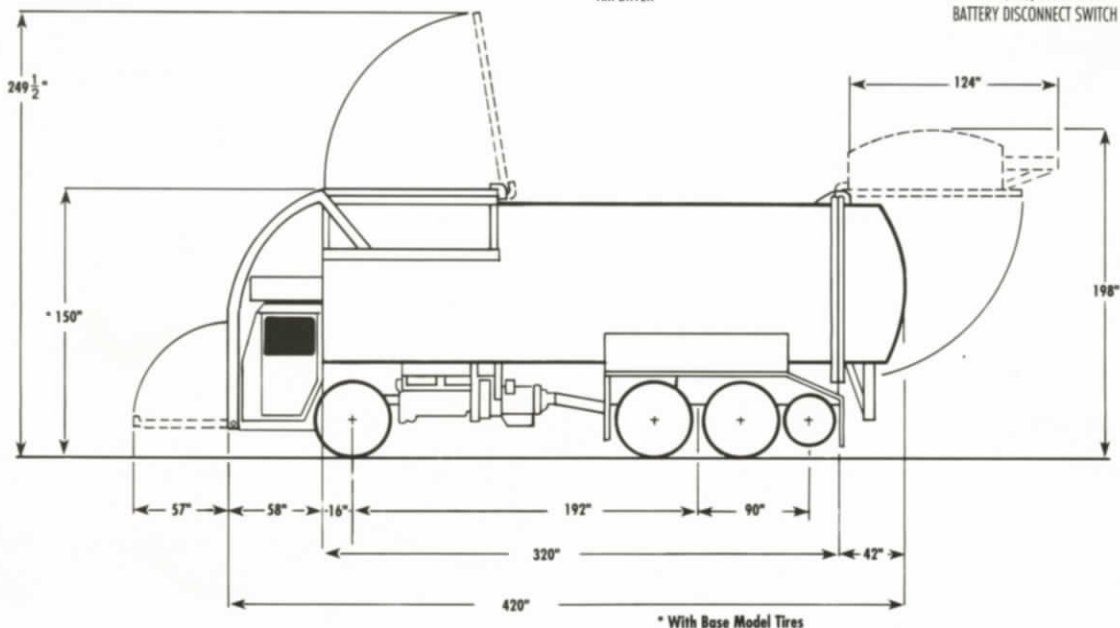

Specifications subject to change without notice.



CRANE CARRIER COMPANY, P.O. BOX 582891, TULSA, OK. 74158 (918) 836-1651