

E-Z Pack[®]

GOLIATH[™] Rear Loader

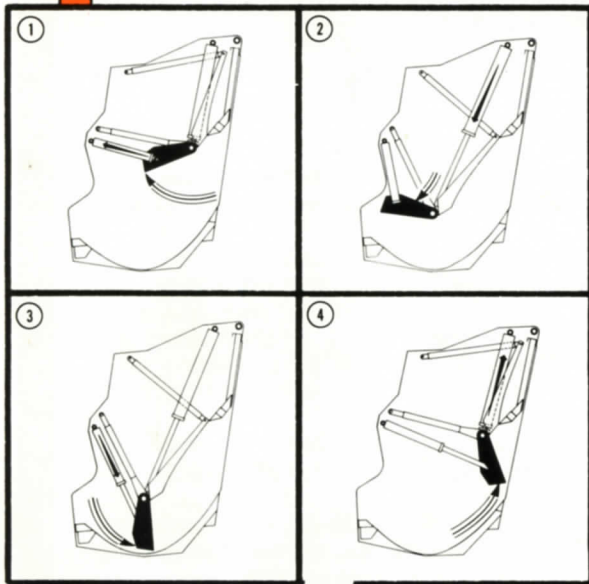

The best equipped rear loader ever built!

E-Z Pack's engineers hand-picked the most efficient and most productive features of all refuse packers. They added a few new ones, most notably automatic lock/unlock tailgate and a unique body design, and combined them with the biggest hopper in the industry, 3.7 cubic yards.



GOLIATH



Optional winch and blade dumper shown.

*Leading with
Quality*

E-Z Pack[®]
Refuse Systems

E-Z Pack® GOLIATH Rear Loader

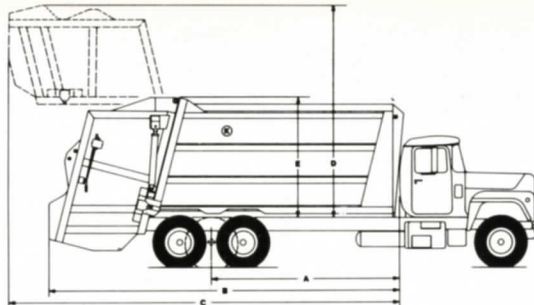

	20 Yd. (18.28m)	25 Yd. (22.86m)	31 Yd. (28.34m)
A. Cab to Trunnion (CT)	126-132" (3200.4-3352.8mm)	156-162" (3962.4-4114.8mm)	190-196" (4826-4978.4mm)
Cab to Axle (CA)	138-144" (3505.2-3657.6mm)	—	—
B. Length (Including Tailgate)	251" (6375.4mm)	285" (7239mm)	325" (8255mm)
C. Length (Tailgate Raised)	284" (7213.6mm)	318" (8077.2mm)	358" (9093.2mm)
D. Height (Tailgate Raised)	174¼" (4425.95mm)	174¼" (4425.95mm)	174¼" (4425.95mm)
E. Height (Above Frame)	97¾" (2482.85mm)	97¾" (2482.85mm)	97¾" (2482.85mm)
F. Inside Body Width	84" (2133.6mm)	84" (2133.6mm)	84" (2133.6mm)
G. Loading Ht. (Below Frame)	5½" (139.7mm)	5½" (139.7mm)	5½" (139.7mm)
H. Loading Opening	80" (2032mm) wide x 64" (1625.6mm) high		
J. Outside Width	96" (2438.4mm)	96" (2438.4mm)	96" (2438.4mm)
K. Weight	13,500 (6123.6kg)	14,100 (6395.76kg)	14,800 (6713.28kg)

Body Sides Hi-Ten	11 ga. (3.038mm)	Ejector Cylinder (1)	20 yd., 6½"-2 stage-D.A. (18.28m, 165.1mm-2 stage-D.A.)
Body Floor Hi-Ten	10 ga. (3.416mm)		25 yd., 6½"-3 stage, D.A. (22.86m, 165.1mm-3 stage-D.A.)
Body Roof Hi-Ten	11 ga. (3.038mm)		31 yd., 7½"-4 stage-D.A. (28.34m, 190.5mm-4 stage-D.A.)
Hopper Sides Hi-Ten	¾" plate (4.74mm)		
Hopper Floor	¼" (T-1) plate (6.35mm)		
Packing Panel Hi-Ten	¼" plate (6.35mm)		
Packing Cylinders (2)	6" (152.4mm) Double Acting	Hydraulic Oil Tank	67 gal. (253.59 liters)
Sweep Cylinders (2)	4" (101.6mm) Double Acting	Hydraulic Pump	30 gpm @ 1200 rpm (113.56 lit./min.)
Tailgate Cylinders (2)	4" (101.6mm) Double Acting	Hyd. Filter (Suction)	50 gpm, 33 micron (189.27 lit./min.)
		Operating Pressure	2000 psi (13,789kpa)

Chassis Specifications

Specifications listed are intended as general guidelines only. Each chassis selection should be made on an analysis of the weight distribution for the particular chassis/packer combination in question including optional equipment and anticipated payloads.

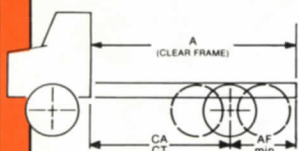

	20 Yd. (18.28m)	25 Yd. (22.86m)	31 Yd. (28.34m)
CA	138-144" (3505.2-3657.6mm)	—	—
CT	126-132" (3200.4-3352.8mm)	156-162" (3962.4-4114.8mm)	190-196" (4826-4978.4mm)
A	172" (4368.8mm)	206" (5232.4mm)	246" (6248.4mm)
AF (min)	32" SA (812.8mm) 44" TA	44" (1117.6mm)	44" (1117.6mm)
GVWR Front	12,000# (5443.2kg)	14,000# (6350.4kg)	18,000# (8164.8kg)
GVWR Rear	29,000# SA (13,154.4kg) 34,000# TA (15,422.4kg)	42,000# (19,051.2kg)	44,000# (19,958.4kg)

Operational Features:

Compaction Cycle—manual hydraulic, automatic split cycle, fully reversible • **Cycle Time**—28-30 seconds • **Reload Time**—10-12 seconds • **Packer Panel**—curved, one-piece construction • **Ejector Panel**—travels on steel guide shoes, floor level track • **Packing Cylinders**—positioned away from refuse for trouble free operation • **Ejector Cylinder**—heavy-duty, double-acting, telescopic.

Standard Equipment:

Manual controls • ICC lights and reflectors meet DOT re-

quirements • Non-skid riding steps at rear corners of tailgate • Curbside buzzer • Automatic latch-unlatch tailgate.

Optional Equipment

Streetside buzzer • Airshift or hot shift PTO's • Front mount and fly wheel PTO's • 1-2 yard (.9144-1.828m) cable and chain type container attachments • 1-3 yard (.9144-2.743m) hydraulic container attachment • 8,000# (3628.8kg) overhead hoists • 14,000# (6350.4kg) reeving cylinder winch • System pressure gauge • Diesel engine kill switch • Return line filter.

Optional container dumping devices handle containers up to 10 cubic yards (7.646 cu. meters).

E-Z Pack®

Refuse Systems

A division of Peabody Galion
P.O. Box 607, Galion, OH 44833-0607
Tel. (419) 468-2120 • FAX (419) 468-4895



Authorized Distributor:

Printed in U.S.A.