



The Big-Mouth Lightweight.

Apollo™ from E-Z Pack®. The lightest mid-range rear loader with the biggest hopper.

Apollo was engineered to use only the most advanced alloy steel available. The result is a stronger body that eliminates excess weight, leaving Apollo up to 1000 lbs. lighter than other rear loaders in its class. This unique lightweight design, plus a big mouth 3 cu. yd. hopper, combine to give you *more capacity*. That means you can collect more yards per stop. Extend the number of stops on your route. And haul bigger payloads...legally...without costly overweight fines.

All to increase your productivity, as well as your profits.

And that's not all. Perfect for residential and commercial collection, Apollo has an exclusive track-less hopper and simplified hydraulics for greater reliability, easy maintenance and less downtime.

What's more, Apollo's loading height is the lowest in its class—5½" below the chassis—for easier loading and less fatigue.

Apollo is available in 16, 18, 20 and 25-yard capacities. You can also add a full range of optional equipment to Apollo, including an automatic lock/unlock tailgate.

With all these superior productivity benefits built in, you might expect Apollo's price to be superior as well. Fact is, Apollo is priced no more than competitive models in its class.

*Leading with
Quality* **E-Z Pack®**
Refuse Systems

APOLLO SPECIFICATIONS

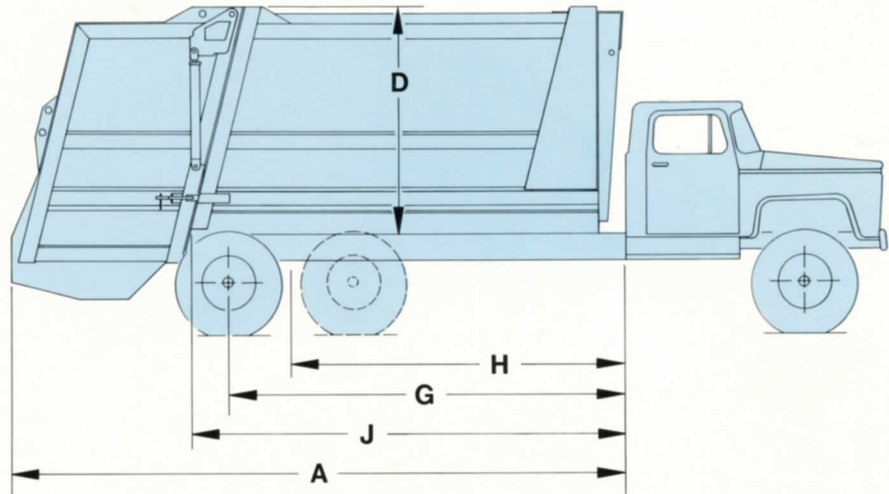
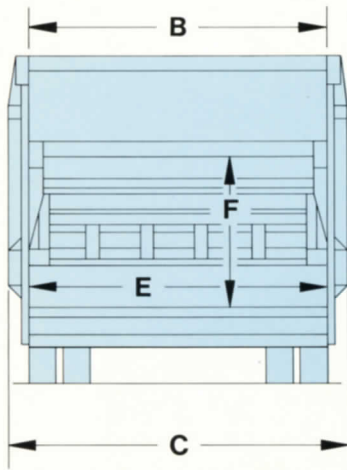

Model Nos.	A300-16	A300-18	AA300-20	A300-25
ABOVE DRAWINGS UNIT DETAIL	16 yd. (12.25 cu. mt.)	18 yd. (13.76 cu. mt.)	20 yd. (15.30 cu. mt.)	25 yd. (19 cu. mt.)
A LENGTH (INCLUDING TAILGATE)	208" (5283mm)	223" (5664mm)	238" (6045mm)	272" (6909mm)
B INSIDE WIDTH (BODY)	86" (2184mm)	86" (2184mm)	86" (2184mm)	86" (2184mm)
C OUTSIDE WIDTH	96" (2438mm)	96" (2438mm)	96" (2438mm)	96" (2438mm)
D HEIGHT (ABOVE CHASSIS FRAME)	90 1/4" (2292mm)	90 1/4" (2292mm)	90 1/4" (2292mm)	90 1/4" (2292mm)
E HOPPER WIDTH	80" (2032mm)	80" (2032mm)	80" (2032mm)	80" (2032mm)
F LOADING OPENING	80" x 58" (2032 x 1473mm)	80" x 58" (2032 x 1473mm)	80" x 58" (2032 x 1473mm)	80" x 58" (2032 x 1473mm)
G CAB-TO-AXLE	108" - 114" (2743 - 2896mm)	120" - 126" (3048 - 3200mm)	138" - 144" (3505 - 3657mm)	N/A N/A
H CAB-TO-TRUNNION	N/A N/A	N/A N/A	126" - 132" (3200 - 3353mm)	156" - 162" 3963 - 4115mm)
J DECK LENGTH	140" (3556mm)	155" (3937mm)	170" (4318mm)	204" (5181mm)
LOADING HEIGHT	Up to 5 1/2" (140mm) below chassis frame	Up to 5 1/2" (140mm) below chassis frame	Up to 5 1/2" (140mm) below chassis frame	Up to 5 1/2" (140mm) below chassis frame
HOPPER CAPACITY	3 cu. yd. (2.3 cu. mt.)	3 cu. yd. (2.3 cu. mt.)	3 cu. yd. (2.3 cu. mt.)	3 cu. yd. (2.3 cu. mt.)
WEIGHT APPROX.	9000 lbs. (4062kg)	9250 lbs. (4195kg)	9500 lbs. (4310kg)	10100 lbs. (4580kg)

OPERATIONAL FEATURES:

COMPACTION CYCLE: Dual level hydraulic, automatic stop point, fully reversible.

CYCLE TIME: Approximately 26 seconds, reload @ 9 seconds.

EJECTOR PANEL: Travels in steel guide shoes, floor level track.

PACKING CYLINDERS: Positioned away from refuse for trouble-free operation.

EJECTOR CYLINDER: Heavy-duty, double-acting, telescopic.

O-RING SEAL FITTINGS: At all high pressure hydraulic connections. Including, fittings, tubing and hoses.

Construction and Operational Details	
Body sides	12 ga. AR (2.66mm)
Body floor	10 ga. AR (3.42mm)
Body roof	12 ga. AR (2.68mm)
Ejector panel	12 ga. Hi-Ten
Hopper sides	3/16" AR plate (4.76mm)
Hopper floor	1/4" Hi-Ten plate (6.35mm)
Packing panel (face plate)	3/16" AR plate (4.76mm)
Oil tank	27 gallon (102 liters)
Packing cylinders	4 1/2" I.D. (D.A.) (114mm)
Sweep cylinders	3 1/2" I.D. (D.A.) (89mm)
Ejector cylinder	16 & 18 cu. yd. — 5 1/2" (D.A.) Tele. (140mm) 20 & 25 cu. yd. — 5 1/2" (D.A.) Tele. (140mm)
Tailgate cylinder (mech. latch)	3 1/2" single acting (89mm)
Tailgate cylinder (auto. latch)	3" I.D. (D.A.) (76mm)
Hydraulic pump	19 G.P.M. (72 liters/min.)
Hydraulic filters	suction — 100 mesh return — 10 micron
Operating pressure	2500 P.S.I. (175 kg/sq. cm.)
NOTE: PTO Requirements are 50 HP @ 1200 RPM (Torque Rating 219 Ft. Lb.)	
SPECIAL NOTE: Chassis equipped with diesel engine requires full variable speed governor.	

OPTIONAL EQUIPMENT:

Streetside Door	10,000# Bloom Winch
High Mount Lights	Cable Reaving Hoist, 14,000#
Hopper Light	Blade Dumper
Streetside Buzzer	Front Pump — Dry Valve
Corner Steps	High Pressure Filter
Rear Flood Lights	Automatic Tailgate Latch
Hydraulic Dumper	

E-Z Pack®

Refuse Systems

A Division of Peabody Galion
 P.O. Box 607 Galion, Ohio 44833-0607 U.S.A.
 1-419-468-2120 1-800-537-9180
 FAX: 1-419-468-4895
 TLX: 987-454 PEABINT GAON

E-Z Pack reserves the right under its Product Improvement Program to modify construction and/or design details and furnish equipment when so altered without reference to illustrations and/or specifications shown herein. All specifications subject to change without notice.

Authorized Distributor

METROPOLITAN WASTE EQUIPMENT, INC.
 1074 TURNPIKE ST.
 STOUGHTON, MA 02072
 (617) 344-8262

Printed in U.S.A.

Form No. EZ-598
 4/91