

# Apollo A-300

MID-RANGE REAR LOADER



*Large hopper, low loading height, "E-Z load" productivity.*



# E-Z Pack

by Clean Earth





**E-Z Pack**  
by Clean Earth

**APOLLO A-300**  
Mid-Range Rear Loader  
**SPECIFICATIONS**

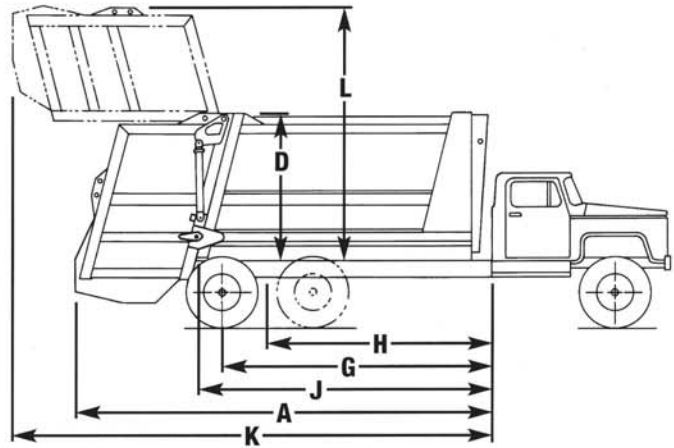
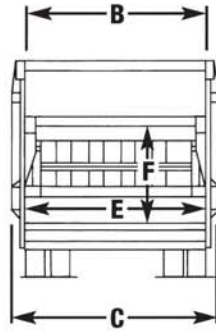

MODEL NO.	A300-18	A300-20	A200-25
Capacity	18 cu. yd. (13.76 cu. m.)	20 cu. yd. (15.30 cu. m.)	25 cu. yd. (19 cu. m.)
A LENGTH (INCLUDING TAILGATE)	223" (5664 mm)	238" (6045 mm)	272" (6909 mm)
B INSIDE WIDTH (BODY)	86" (2184 mm)	86" (2184 mm)	86" (2184 mm)
C OUTSIDE WIDTH	96" (2438 mm)	96" (2438 mm)	96" (2438 mm)
D HEIGHT (ABOVE CHASSIS FRAME)	90-1/4" (2292 mm)	90-1/4" (2292 mm)	90-1/4" (2292 mm)
E HOPPER WIDTH	80" (2032 mm)	80" (2032 mm)	80" (2032 mm)
F LOADING OPENING	80" x 58" (2032 x 1473 mm)	80" x 58" (2032 x 1473 mm)	80" x 58" (2032 x 1473 mm)
G CAB-TO-AXLE	120"-126" (3048 - 3200 mm)	138" - 144" (3505 - 3353 mm)	N/A N/A
H CAB TO TRUNNION	N/A N/A	126" - 132" (3200 - 3353 mm)	156" - 162" (3963 - 4115 mm)
J DECK LENGTH	155" (3937 mm)	170" (4318 mm)	204" (5181 mm)
K LENGTH T.G. RAISED	262" (6655 mm)	277" (7036 mm)	311" (7899 mm)
L HEIGHT T.G. RAISED	156" (3950 mm)	156" (3950 mm)	156" (3950 mm)
LOADING HEIGHT	Up to 5-1/2" (140 mm) below chassis frame	Up to 5-1/2" (140 mm) below chassis frame	Up to 5-1/2" (140 mm) below chassis frame
HOPPER CAPACITY	3 cu. yd. (2.3 cu. m.)	3 cu. yd. (2.3 cu. m.)	3 cu. yd. (2.3 cu. m.)
WEIGHT	9,900 lb.	10,250 lb.	11,000 lb.

\*Chassis specifications listed are intended as general guidelines only. Each chassis selection should be made on an analysis of the weight distribution for the particular chassis/packer combination including optional equipment and anticipated payloads.

CONSTRUCTION AND OPERATIONAL DETAILS	
Body Sides	10 ga. 50,000 PSI (3.42 mm)
Body Floor	7 ga. 50,000 PSI (4.78 mm)
Body Roof	10 ga. 50,000 PSI (3.42 mm)
Ejector Panel	7 ga. 50,000 PSI (4.78 mm)
Hopper Sides	Lower 1/4" 100,000 PSI (6.35 mm) Upper 7 ga. 50,000 PSI (4.78 mm)
Hopper Floor	1/4" 100,000 PSI (6.35 mm)
Packing Panel	1/4" 50,000 PSI (6.35 mm)
Oil Tank	37 gal. (140 liters)
Packing Cylinders (2)	4-1/2" I.D. (D.A.) (114 mm)
Sweep Cylinders (2)	4" I.D. (D.A.) (102 mm)
Tailgate Cylinders (auto latch)	3" I.D. (D.A.) (76 mm)
Ejector Cylinder (1)	18 / 20 cu. yd. (2 stage) — 5-1/2" (D.A.) Tele (140 mm) 25 cu. yd. (3 stage) — 5-1/2" (D.A.) Tele (140 mm)
Tailgate Cylinder (auto. latch)	3" I.D. (D.A.) (76 mm)
Hydraulic Pump	27 GPM @ 1200 RPM
Hydraulic Filters	suction — 100 mesh return — 10 micron
System Operating Pressure	2500 PSI (175 kg/sq. cm.)
NOTE: PTO Requirements are 39 HP @ 1200 RPM (Torque Rating 212 Ft. Lb.) Minimum	
SPECIAL NOTE: Chassis must Be equipped with diesel engine and requires variable speed governor.	

**Standard Equipment:**

- Manual Controls
- Gate Props
- Back Up Alarm
- Body Lifting Eyes
- High Mount Light Package
- ICC Lights and Reflectors Meet DOT Requirements
- Non-Skid Riding Steps at Rear Corners of Tailgate
- Streetside and Curbside Buzzers
- Automatic Latch-Unlatch Tailgate

**Optional Equipment:**

- Airshift or Hot Shift PTO's
  - Streetside Access Door
  - Front Mount Pump
  - Dual Hopper Flood Lights
  - 10,000# (4535 kg) Overhead Winch\*
  - 14,000# (6350.4 kg) Reeving Cylinder Winch\*
  - System Pressure Gauge
  - 1-3 Yard (.76-2.3 m<sup>3</sup>) Hydraulic Container Attachment
- \*Optional Container Dumping Devices Handle Containers up to 10 Cubic Yards (7.646 cu. Meters).

**Operational Features:**

COMPACTION CYCLE: Manual hydraulic, automatic split cycle, fully reversible.  
CYCLE TIME: 26 seconds, reload @ 9 seconds.  
PACKER PANEL: Curved, one-piece construction.  
EJECTOR PANEL: Travels in steel guide shoes, floor level track.  
PACKING CYLINDERS: Positioned away from refuse for trouble-free operation.  
EJECTOR CYLINDER: Heavy-duty, double-acting, telescopic.

Clean Earth Environmental Group, LLC reserves the right under its Product Improvement Program to modify construction and/or design and furnish equipment without reference to illustrations and/or specifications shown herein. All specifications subject to change without notice.

**Authorized Distributor:**



**CLEAN EARTH**  
ENVIRONMENTAL GROUP, LLC

P.O. Box 790 · 200 Ladish Road · Cynthiana, KY 41031  
Phone 859-234-1100 · Fax 859-234-0061 · www.cleanearthllc.com