

Goliath G-370

HIGH-COMPACTION COMMERCIAL REAR LOADER



The industry leader in heavy-duty, high compaction.



E-Z Pack[®] by Clean Earth



E-Z Pack
by Clean Earth

Goliath G-370
High-Compaction Rear Loader
SPECIFICATIONS

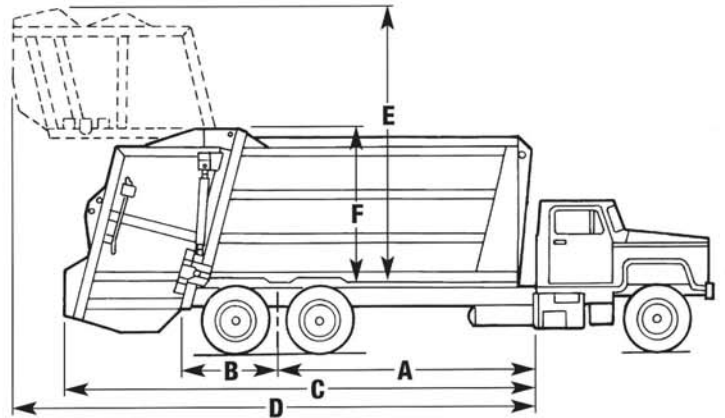
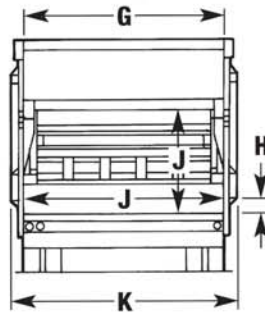

MODEL NO.	G-370-20	G-370-25	G-370-31
Capacity	20 cu. yd. (15.3 cu. m.)	25 cu. yd. (19.1 cu. m.)	31 cu. yd. (23.7 cu. m.)
A CAB-TO-TRUNNION (CT)	126" - 132" (3200.4-3352.8mm)	156" - 162" (3962.4-4114.8mm)	190" - 196" (4826 - 4978.4mm)
CLEAR PLATFORM	172" (4368.8 mm)	206" (5232.4 mm)	246" (6248.4 mm)
B TRUNNION TO FRAME END	44" AF min. (1117.6 mm)	44" AF min. (1117.6 mm)	44" AF min. (1117.6 mm)
C LENGTH (INCLUDING TAILGATE)	251" (6375.4 mm)	285" (7239 mm)	325" (8255 mm)
D LENGTH TAILGATE RAISED	284" (7213.6 mm)	318" (8077.2 mm)	358" (9093.2 mm)
E HEIGHT TAILGATE RAISED	174.25" (4425.95 mm)	174.25" (4425.95 mm)	174.25" (4425.95 mm)
F HEIGHT (ABOVE CHASSIS FRAME)	97.75" (2482.85 mm)	97.75" (2482.85 mm)	97.75" (2482.85 mm)
G INSIDE WIDTH (BODY)	84" (2133.6 mm)	84" (2133.6 mm)	84" (2133.6 mm)
H LOADING HEIGHT (BELOW FRAME)	5.5" (139.7 mm)	5.5" (139.7 mm)	5.5" (139.7 mm)
J LOADING OPENING	80" (2032 mm) wide x 64" (1625.6 mm) high		
K OUTSIDE WIDTH	96" (2438.4 mm)	96" (2438.4 mm)	96" (2438.4 mm)
L WEIGHT	14,500# (6577 kg)	15,200# (6895 kg)	16,000# (7301 kg)

*Chassis specifications listed are intended as general guidelines only. Each chassis selection should be made on an analysis of the weight distribution for the particular chassis/packer combination including optional equipment and anticipated payloads.

CONSTRUCTION AND OPERATIONAL DETAILS	
Body Sides	10 ga. 100,000 PSI (3.42 mm)
Rear Body Side Liner	3/16" 50,000 PSI (4.76 mm)
Body Floor	1/4" 100,000 PSI (6.35 mm)
Body Roof	10 ga. 100,000 PSI (3.42 mm)
Ejector Panel	10 ga. 100,000 PSI (3.42 mm)
Hopper Sides	lower 1/4" 100,000 PSI (4.76 mm)
Hopper Floor	1/4" 100,000 PSI (6.35 mm)
Packing Panel	1/4" 100,000 PSI (6.35 mm)
Packing Cylinders (2)	6" (152.4 mm) (D.A.)
Sweep Cylinders (2)	4" (101.6mm) (D.A.)
Tailgate Cylinders (2)	4" (101.6mm) (D.A.)
Ejector Cylinder (1)	20 yd. 6-1/2" 2-Stage 25 yd. 6-1/2" 3-Stage 31 yd. 7-1/2" 4-Stage
Hydraulic Oil Tank	67 gal. (253.59 liters)
Hydraulic Pump	30 GPM @ 1200 RPM (113.56 lit./min.)
Hydraulic Filters	suction - 100 mesh return - 10 micron
System Operating Pressure	2500 PSI (17,236 kpa)
NOTE: PTO Requirements are 45 HP @ 1200 RPM (Torque Rating 250 Ft. Lb.) Minimum	
SPECIAL NOTE: Chassis MUST be equipped with diesel engine and requires variable speed governor.	

Standard Equipment:

- Manual Controls
- Gate Props
- Back Up Alarm
- Body Lifting Eyes
- High Mount Light Package
- ICC Lights and Reflectors Meet DOT Requirements
- Non-Skid Riding Steps at Rear Corners of Tailgate
- Streetside and Curbside Buzzers
- Automatic Latch-Unlatch Tailgate

Optional Equipment:

- Airshift or Hot Shift PTO's
- Streetside Access Door
- Front Mount Pump
- Dual Hopper Flood Lights
- 10,000# (4535 kg) Overhead Winch*
- 14,000# (6350.4 kg) Reeving Cylinder Winch*
- System Pressure Gauge
- 1-3 Yard (.76-2.3 m³) Hydraulic Container Attachment

*Optional Container Dumping Devices Handle Containers up to 10 Cubic Yards (7.646 cu. Meters).

Operational Features:

COMPACTION CYCLE: Manual hydraulic, automatic split cycle, fully reversible.
CYCLE TIME: 28-30 seconds, reload @ 10-12 seconds.
PACKER PANEL: Curved, one-piece construction.
EJECTOR PANEL: Travels in steel guide shoes, floor level track.
PACKING CYLINDERS: Positioned away from refuse for trouble-free operation.
EJECTOR CYLINDER: Heavy-duty, double-acting, telescopic.

Clean Earth Environmental Group, LLC. reserves the right under its Product Improvement Program to modify construction and/or design and furnish equipment without reference to illustrations and/or specifications shown herein. All specifications subject to change without notice.

Authorized Distributor:



CLEAN EARTH
ENVIRONMENTAL GROUP, LLC

P.O. Box 790 · 200 Ladish Road · Cynthiana, KY 41031
Phone 859-234-1100 · Fax 859-234-0061 · www.cleanearthllc.com