

E-Z Pack® M-200

Rear Loader for High Volume Municipal Use



The M-200 manually operated Rear Loader is specifically designed for municipal and contractor operations where handling high volume residential routes is a must.

- Manual controls feature "safety stop" of packer panel travel before reaching pinch point and can also reverse the panel at any point of the compaction cycle for maximum maneuverability and crew safety.
- Low sill, unobstructed 2 cu. yd. hopper has a wide loading area so two men can load at the same time.
- One-piece packing panel sweeps hopper bottom quickly, quietly, and cleanly so crew can reload hopper in just 12 seconds.
- Tailgate lifts high to allow telescopic cylinder to extend the curved ejector blade beyond the body for fast, clean ejection of all refuse.

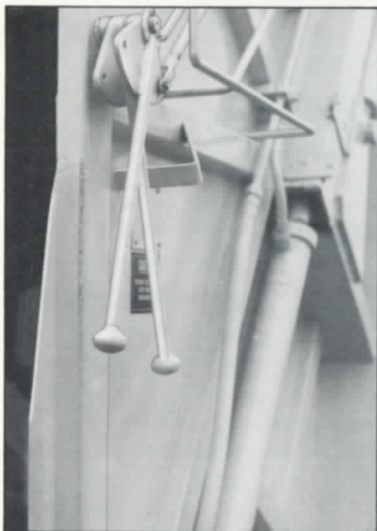

These four distinctive features are just some of the many benefits you get from engineering simplicity into design.

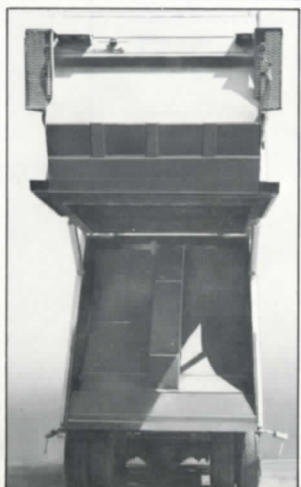

Put our strength behind you.

Peabody Solid Wastes Management
Galion, Ohio 44833

E-Z Pack® M-200

Rear Loaders Especially Designed for Municipal Use.

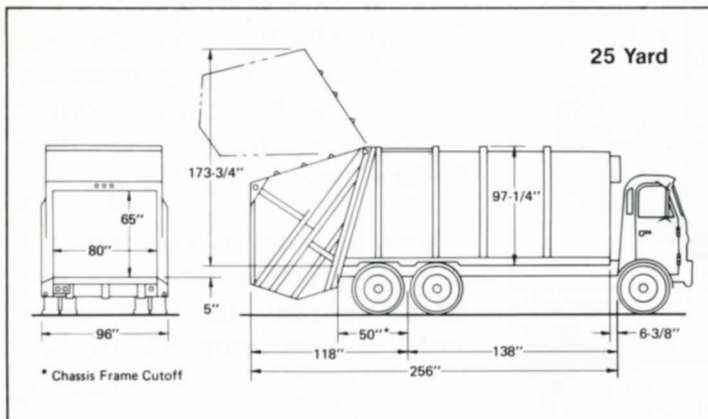
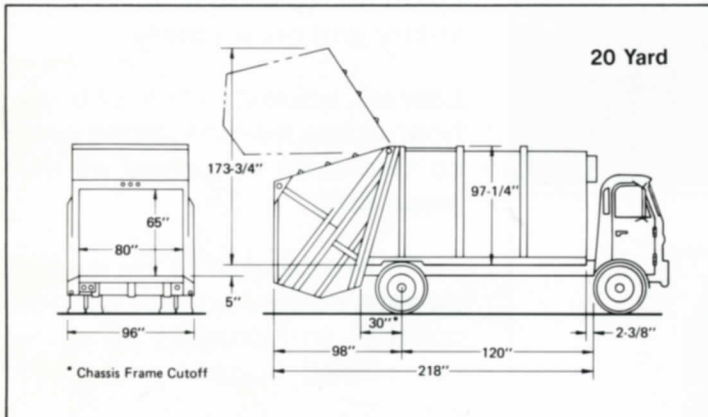
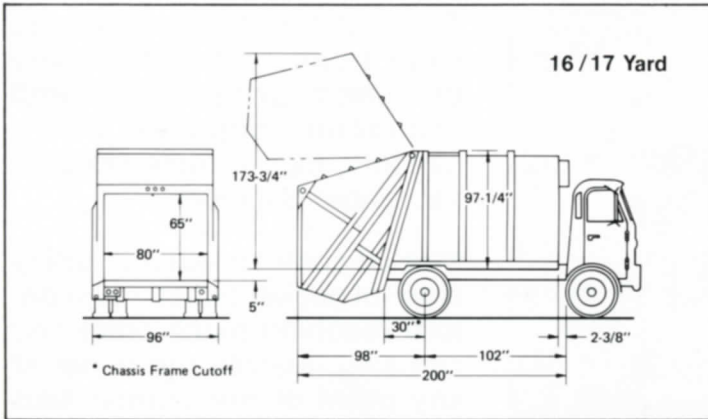

Operational Features

- Compaction Cycle
 - Manually-Operated with Safety Stop Cycle
- Cycle Time
 - 20 Seconds (approximately)
- Packer Panel
 - Curved, One-Piece Construction
- Ejector Panel
 - Steel Guide Shoes, Floor Level Track
- Packing Cylinders
 - Positioned Away from Refuse for Clean Operation
- Ejector Cylinder
 - Telescopic
- Loading Height
 - Up to 5" Below Chassis Frame
- Optional Container Dumping Devices
 - Handle Containers up to 10 Cubic Yards.

General Specifications

	16 / 17 Yard	20 Yard	25 Yard
Body Length			
Including Hopper	197 ⁵ / ₈ "	215 ⁵ / ₈ "	249 ⁵ / ₈ "
Body Width (inside)	89"	89"	89"
Body Height (inside)	84"	84"	84"
Hopper Capacity	2 cu. yds.	2 cu. yds.	2 cu. yds.
Approx. Body Weight	10,700 lbs.	11,000 lbs.	11,500 lbs.
Cab-to-Axle	102"	120"	—
Cab-to-Trunnion	—	—	138"

Put our strength behind you.

DISTRIBUTED BY



Galion, Ohio 44833

The Proven Authority on Solid Wastes Handling Equipment and Systems
Makers of Equipment and Systems with the E-Z Pack Trademark

ALL SPECIFICATIONS SUBJECT TO CHANGE WITHOUT NOTICE.

©1974 Peabody Galion Corporation Form No. EZ-404-PSWM Printed in U.S.A.