



## **CITYPRESS**

*When it comes to low-density waste materials,  
here's the professional*

- optimum cost package* ■
- specialised refuse vehicle* ■
- durable* ■

# Cost-effective collection of low-density waste materials

The CITYPRESS refuse-collection vehicle is the specialist for collecting low-density waste. The CITYPRESS is a lightweight version of that proven all-rounder, the VARIOPRESS, FAUN has come up with the ideal cost-cutting alternative for low-density waste materials. A lighter tailgate, combined with the lightweight CITYPRESS chassis has led to a reduction in running costs and capital outlay.

Yet when it comes to volume the CITYPRESS refuse truck is a giant, and is capable of packing up to 27 m<sup>3</sup> of waste material.

## Robust slide travel

① The high-strength steel-steel material combination makes for durable roller-bearing support.

## Everything under control

④ All the control functions are available in a compact operating unit located at the rear of the vehicle. The operators have everything in their sight and under control, a decisive contribution to safety. Four operating modes are available: continuous operation; single-cycle mode (after one pass the vehicle returns to the starting position); individual activation of each step; and semi-automatic.



## How it compacts

An ingenious design for perfect compaction:

- ① Starting position
- ② The packer plate open
- ③ The carrier plate down and the hopper shut
- ④ The hopper is emptied
- ⑤ The refuse is compacted as the carrier plate ascends



An  
⑤  
CITY  
an  
the  
the  
Th

**Controllable compaction**

② The double-acting telescopic cylinder situated on the ejection plate allows



the operatives to regulate the back pressure. Thanks to the compaction control the pressure can be adapted to suit the requirements of the material being collected in each case. Secondary materials thus remain separable as a result of the lower pressure.

**Increased volume**

③ The ejection plate is designed to allow it to be brought into the furthest forward position, right up against the driver's cab. This leads to an increase in volume with the same wheelbase and the same unladen weight, not to mention improved front axle loading.

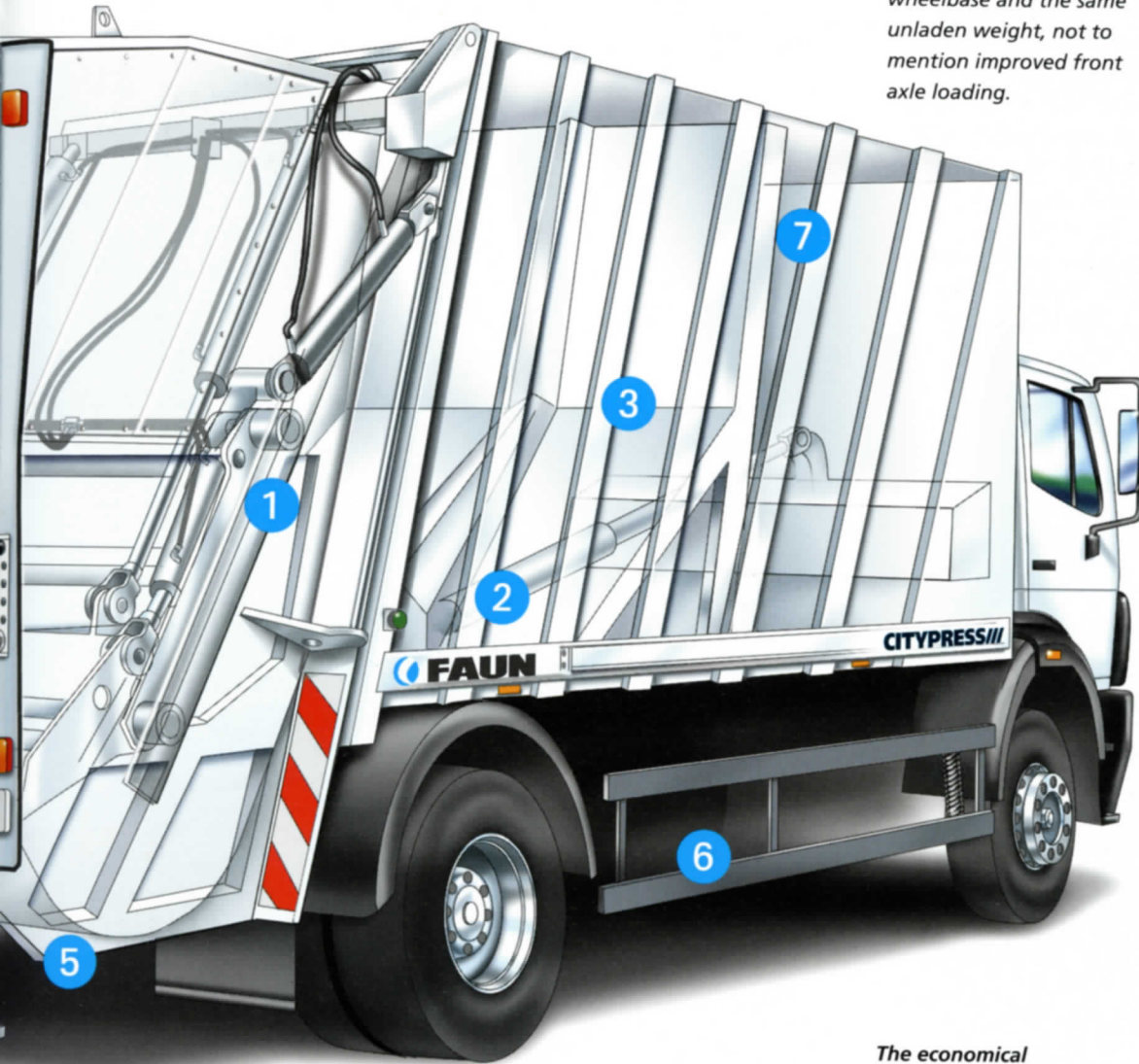

**Ecological throughout**

⑦ The CITYPRESS has been consistently thought through with regard to ecological considerations. As an optional CITYPRESS feature, both recyclables and waste materials can be sprayed with an odour neutraliser, thus allowing the vehicle operatives to breathe more easily.

**An attractive tailgate**  
④ The tailgate of the CITYPRESS is narrower and shorter than that of the VARIOPRESS and thus, of course, lighter. The loading hopper is

designed solely for the most common loading method for low-density waste material, i.e. hand-loaded bags. It goes without saying, that a bin lifter can also be fitted.

**The economical lightweight**

⑥ This is one refuse truck that really does travel light! The CITYPRESS weighs significantly less than the VARIOPRESS, which of course leads to a reduction in fuel consumption costs.

**The solution for a cleaner environment.**



# Plenty of volume for your money

The CITYPRESS is the little brother of the VARIOPRESS – which means that it offers the many proven features and the reliable tried-and-tested engineering and quality that comes with the VARIOPRESS. The CITYPRESS is the cost-effective specialist when it comes to recycleables. It offers more volume yet weighs less. CITYPRESS provides the basis for optimum-cost refuse disposal. The designers have achieved significant savings on weight, especially in the tailgate. An attractive design, top-notch quality and a genuine economical alternative – advantages that make the CITYPRESS stand out from the competition.

FAUN is the dedicated partner of waste disposal management. From the close dialogue with our customers throughout Europe we can offer tailor-made equipment for every conceivable task. Also what you get: Because of the great choice of different vehicles and the assembly of pre-fabricated machine parts, with FAUN you always get fitting and hence economic solutions. As a single supplier FAUN, with its modern production, is also able to process large orders just in time – to the well known consistently high quality of course. Best of all, with our after-sales service provision our customers get: suitable financing modules such as leasing and hiring, free logistics advice, training for your personnel, the concentrated network of service stations and dealer agencies, individual FAUN maintenance contracts and the FAUN mobility guarantee.

A full range of bins and containers can be loaded by the CITYPRESS.

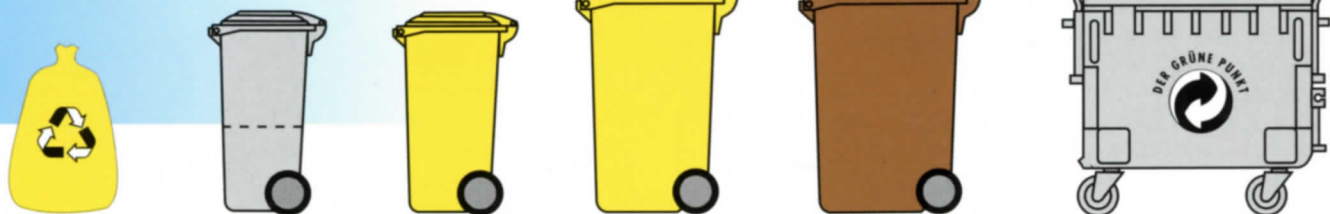

## TECHNICAL DATA CITYPRESS

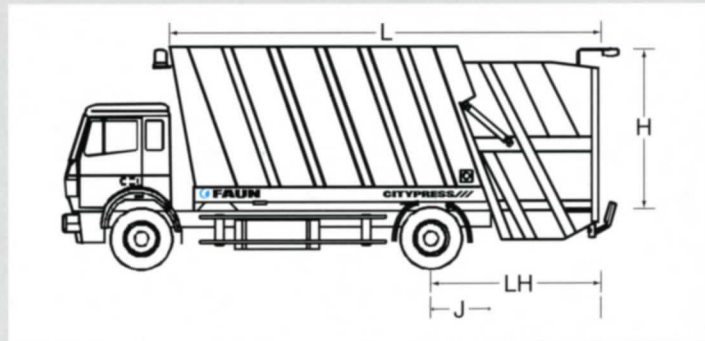

BODY		210/24	210/27
Body capacity	m <sup>3</sup>	24	27
Weight appr. <sup>1)</sup>	kg	5,570	6,220
Length appr.	mm	7,850	7,850
Width appr.	mm	2,500	2,500
Height appr.	mm	2,495	2,695

RECOMMENDED CHASSIS <sup>2)</sup>		210/24	210/27
G. V. W.	t	15	18
Weight appr.	kg	4,500	5,390
Wheelbase			
Standard cab appr.	mm	4,840	4,840
Wheelbase			
Medium cab appr.	mm	–	5,350
Frame overhang	mm	1,150	1,150

EXAMPLE COMPLETE VEHICLE <sup>3)</sup>		210/24	210/27
Height unladen appr.	mm	3,400	3,670
Height, tailgate open appr.	mm	5,300	5,500
Length appr.	mm	9,430	9,430
Overhang appr. <sup>4)</sup>	mm	2,450 + 750	2,450 + 750
Weight appr.	kg	10,070	11,610
Payload <sup>4)</sup>	kg	4,930	6,390

- 1) Including auxiliary frame (acc. DIN 70020)
- 2) Variations possible depending on chassis and optional equipment
- 3) Measurement from middle of last axle to rear edge of tailgate, variations possible depending on chassis
- 4) Payload will decrease when mounting optional or special equipment to chassis or body. Payload achieved may vary depending on density of collected material.

**FAUN**  
KIRCHHOFF GROUP

FAUN Expotec GmbH  
Stefanstraße 2  
D-58638 Iserlohn  
Tel.: ++49 23 71 / 82 93-00  
Fax: ++49 23 71 / 82 93-09  
Internet: www.FAUN.com  
E-Mail: info@FAUN.com