



Renault Puncher

Refuse collection truck



RENAULT PUNCHER 4 x 2

Refuse collection truck

with 14.5m³ rear loading capacity

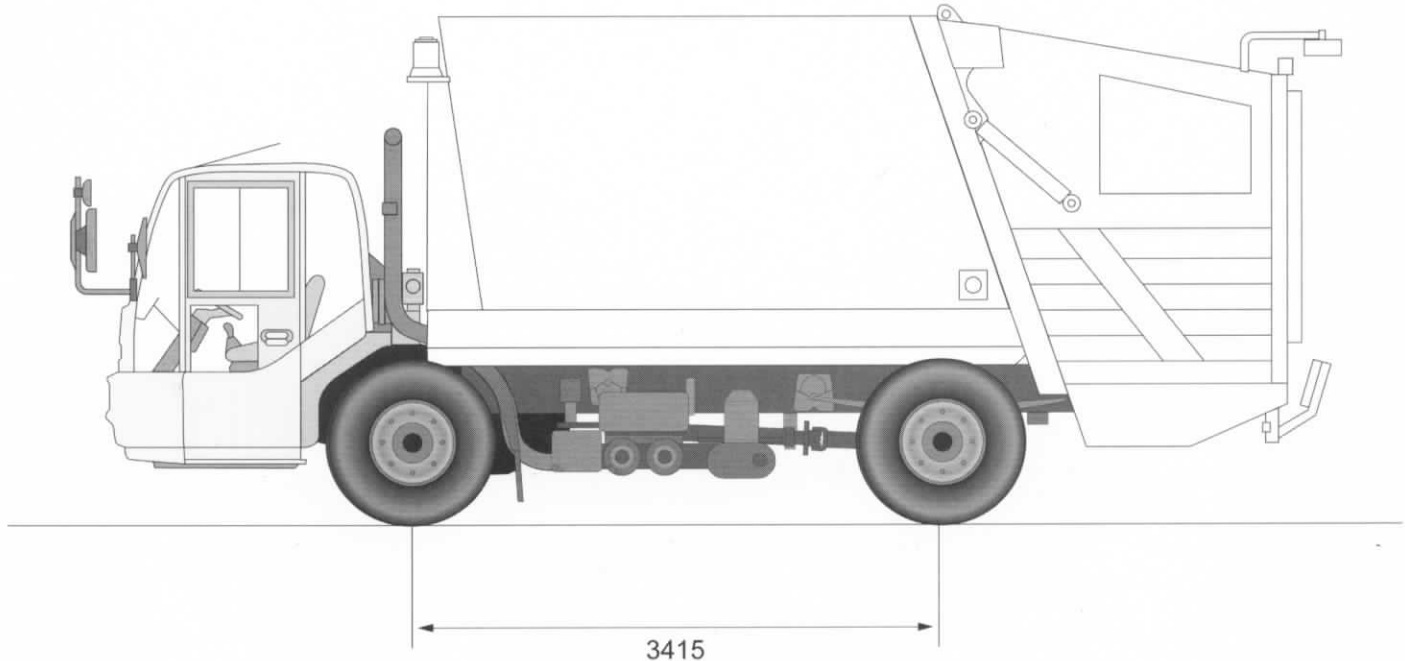

Range	Silhouette	Model	Wheelbase	GVW	Width	Body	Volume
PUNCHER	4x2	270.19	3415	18 T	2360 mm	Variopress 3	14.5 m ³

Equipment / Application :

Rigid vehicles, with a "rear loading" refuse collection body.
 Low cab entry allowing easy, quick and safe access to the cab interior.

RENAULT Puncher has been developed and adapted for rigorous use combined with simple and efficient refuse collecting.

- Chassis with low cab position in order to offer the best load capacity (payload and volume) with the best refuse compactness.
- Reduced chassis width and short wheelbase results in a compact vehicle with an excellent turning radius.
- Hub reduction rear axle and rear air suspension result in safe access to the most hazardous of landfill / waste disposal sites.

Standard Characteristics	Puncher 270.19 4x2
Chassis dimensions: 300 x 80 x 7 mm	X
Allison automatic gearbox	X
Hydrocar gearbox PTO (Torque: 400Nm ; gear: 0.93) shaft outlet	X
Front parabolic suspension with anti-roll bar	X
Rear air suspension with anti-roll bar	X
Front: 315/60 R22.5, tyres XZU Rear: 275/70 R22.5, tyres XZU	X
Without spare wheel	X
Lowered cab: flat floor: folding passenger door + sliding window	X
Kerb to kerb turning radius	6600 mm
Mandatory option	

RENAULT PUNCHER 6 x 2*4

Refuse collection truck

with 20m³ rear loading capacity

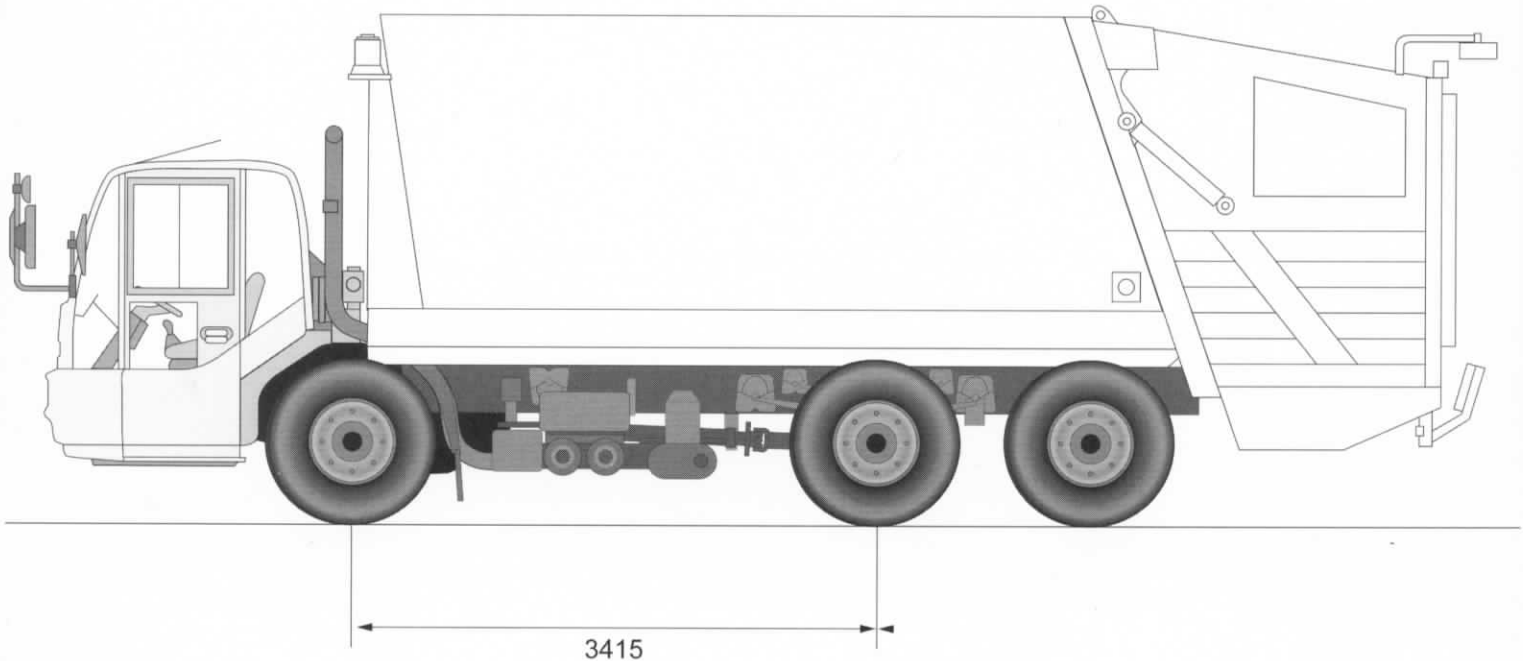

Range	Silhouette	Model	Wheelbase	GVW	Width	Body	Volume
PUNCHER	6 x 2*4	270.26	3415 + 1387	25 T	2360 mm	Variopress 3	20 m ³

Equipment / Application :

Rigid vehicles, with a "rear loading" refuse collection body.
Low cab entry allowing easy, quick and safe access to the cab interior.

RENAULT Puncher has been developed and adapted for rigorous use combined with simple and efficient refuse collecting.

- Chassis with low cab position in order to offer the best load capacity (payload and volume) with the best refuse compactness.
- Reduced chassis width and short wheelbase results in a compact vehicle with an excellent turning radius.
- Hub reduction rear axle and rear air suspension result in safe access to the most hazardous of landfill / waste disposal sites.

Standard Characteristics	Puncher 270.26 6x2*4
Chassis dimensions: 300 x 80 x 7 mm	X
Allison automatic gearbox	X
Hydrocar gearbox PTO (Torque: 400Nm ; gear: 0.93) shaft outlet	X
Front parabolic suspension with anti-roll bar	X
Rear air suspension with anti-roll bar	X
Front: 315/60 R22.5, tyres XZU Rear: 275/70 R22.5, tyres XZU and 315/60 R22.5, tyres XZU	X
Without spare wheel	X
Lowered cab: flat floor: folding passenger door + sliding window	X
Kerb to kerb turning radius	6600 mm
Mandatory option	

RENAULT PUNCHER 6 x 2*4

Refuse collection truck

with 26m³ rear loading capacity

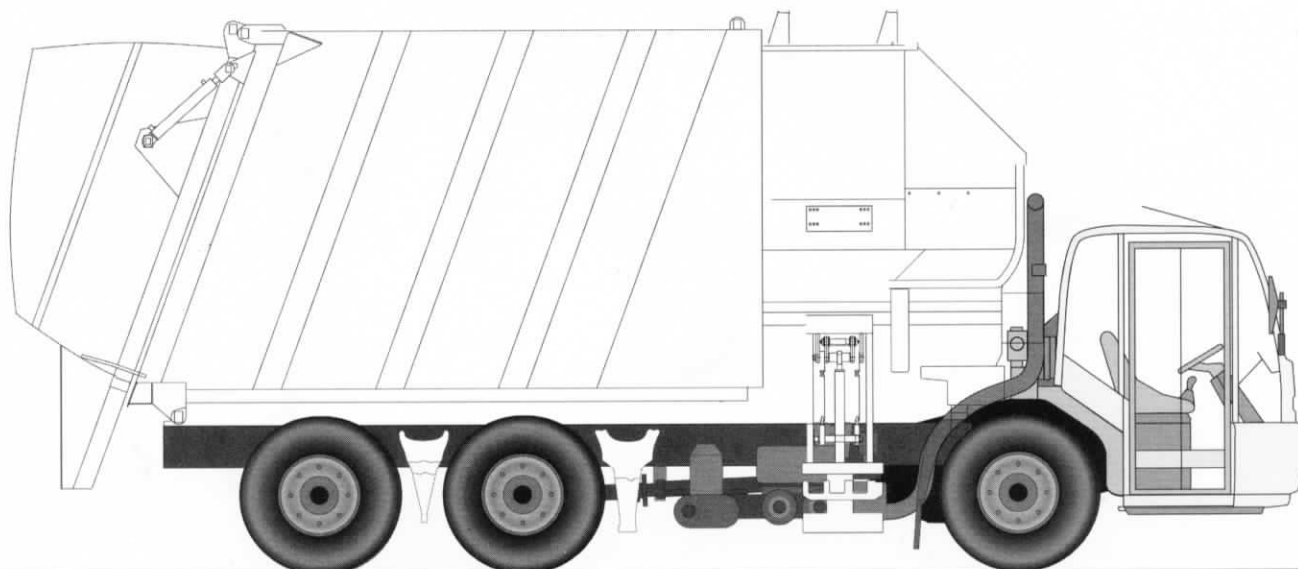

Range	Silhouette	Model	Wheelbase	GVW	Width	Body	Volume
PUNCHER	6 x 2*4	270.26	4015 + 1387	26 T	2500 mm	Sidepress	26 m ³

Equipment / Application :

Rigid vehicle with a "side loading" tipping refuse collection body.
Low cab entry allowing easy, quick and safe access to the cab interior.

RENAULT Puncher has been developed and adapted for rigorous use combined with simple and efficient refuse collecting.

- Three-axle rigid, long, completely clear wheelbase, to allow fitment of side loading equipment.
- Rear steering axle for an excellent turning radius.
- Hub reduction rear axle and rear air suspension result in safe access to the most hazardous of landfill / waste disposal sites.

Standard Characteristics	Puncher 270.26 6x2*4
Chassis dimensions: 300 x 80 x 7 mm	X
Allison automatic gearbox	X
Hydrocar gearbox PTO (Torque: 400Nm ; gear: 0.93) shaft outlet	X
Rear air suspension with anti-roll bar	X
315/80 R22.5, tyres XZE	X
Without spare wheel	X
Lowered cab: flat floor: folding passenger door + sliding window	X
Kerb to kerb turning radius	7580 mm
Mandatory option	
20207: Refuse body pre-equipment	X
20208: Pre-disposition for side loading refuse collection	X

Non-contractual and non-exhaustive document. Contact us for information on other models.

RENAULT TRUCKS UK LTD

Boscombe Road - Dunstable - Beds - LU5 4LX

www.renault-trucks.co.uk

FAUN MUNICIPAL SERVICE VEHICLES LTD

Bryn Cefni Industrial Estate - Llangefni
Isle of Anglesey - North Wales - LL77 7XA