



# GLOVER TYPE '202' REFUSE VEHICLE



## Featuring:

British design and manufacture.

Designed for simplicity of maintenance and operation.

Robust all-welded steel construction.

Smooth quiet operation with hydraulic motor drive in place of complicated ram operated systems.

Large capacity hopper with low loading height.

Fast loading continuous or intermittent operation.

Designed for most popular makes of chassis.

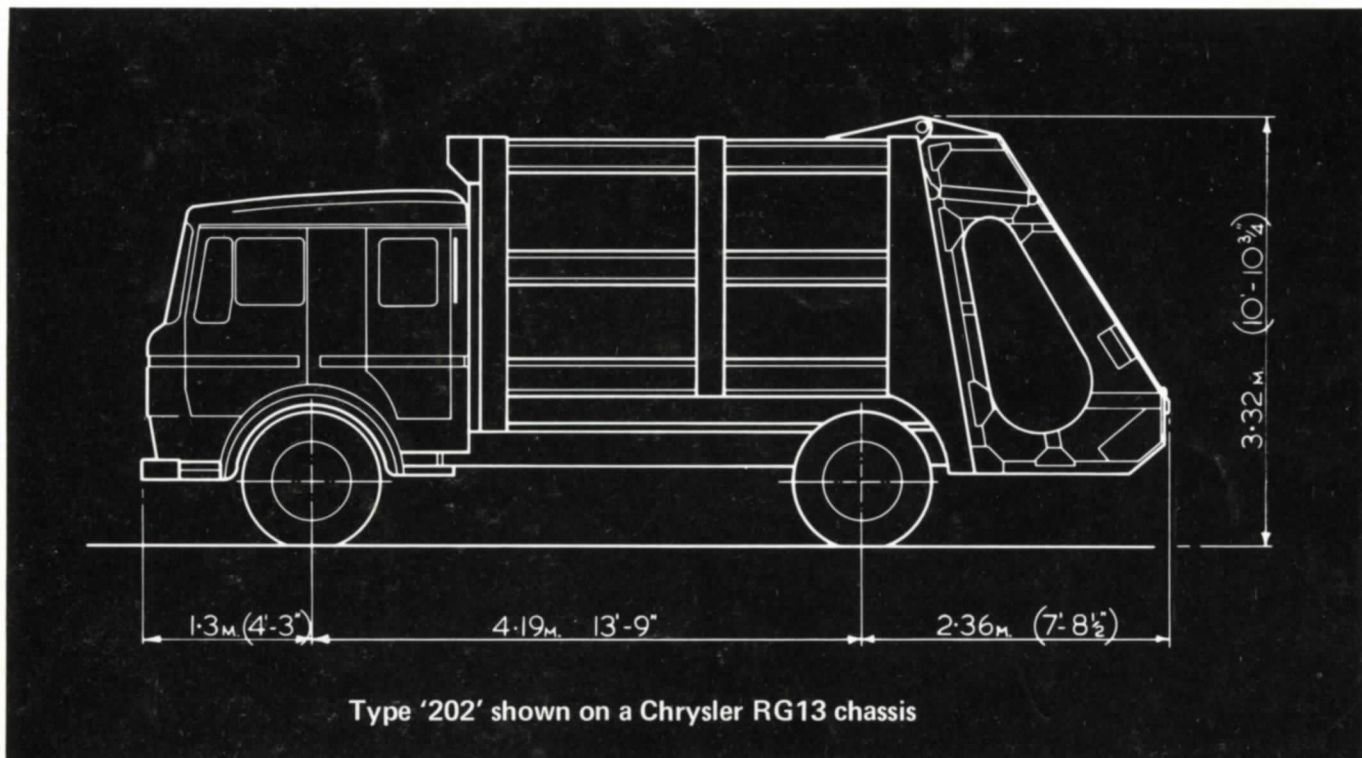

## Specification

### Body and Hopper Construction

All-welded zinc-coated steel with Cor-ten floor sweep plate and other wearing areas.

### Packer Mechanism

Heavy duty packer plate carried on crank assemblies with pivoting top links and driven through roller chains by hydraulic motor and epicyclic reduction gear box. Hopper fitted with robust top hinges and lifted by single acting rams with safety check valves. Hydraulic wedge-type locks secure hopper to body during loading.

### Hydraulic System

Large capacity hydraulic tank at front of body with suction filter and engine driven gear type hydraulic pump protected by a full-flow relief valve incorporating a

dump valve to pass oil back to tank when hydraulic services are not required. Separate control valves for operating hydraulic motor packer drive, discharge barrier and hopper lift.

### Controls

Push-buttons on loading hopper for start, stop and reverse operation of packer mechanism and selector switch for continuous or intermittent operation. Controls in cab include hand throttle, control for engaging pump operation and remote controls for hopper lift and discharge barrier.

### Safety Features

Full-width emergency stop bar on loading hopper. Rubber curtains in hopper and across lower edge of packer plate.

## GENERAL DATA

|                                 |   |  |
|---------------------------------|---|--|
| <b>Body Capacity</b>            | : | 13.76 cu.m. (18 cu.yds.)                       |
| <b>Overall Height</b>           | : | 3.32m. (10' 10 <sup>3</sup> / <sub>4</sub> "") |
| <b>Overall Width</b>            | : | 2.44m. ( 8' 0"                                 |
| <b>Hopper Capacity</b>          | : | Approx. 1.15 cu.m. (1.5 cu.yds.)               |
| <b>Hopper Width (inside)</b>    | : | 1.85 m.(73"                                    |
| <b>Loading Height (unladen)</b> | : | 1.22 m. (48"                                   |
| <b>Compaction ratio</b>         | : | 4.5 to 1 for average loads                     |
| <b>Packer rate</b>              | : | Up to 4 cycles/min. (continuous)               |

# Glover Webb & Liversidge Limited Municipal Vehicles

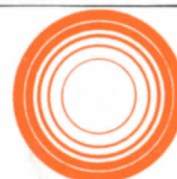

**Sales & Marketing**  
**Home & Overseas**

**Service**

### GLOVER—HAMBLE

Hamble Lane, Hamble, Hampshire, SO3 5NY.  
Telephone: 042-122-2811 Telex: 477527

### CHARROLD—HUNTINGDON

St Peter's Road, Huntingdon, Cambs. PE18 7DL.  
Telephone: 0480-54385 Telex: 32216