

GLOVER

TYPE '202'

REFUSE VEHICLE



Featuring:

British design and manufacture.

Designed for simplicity of maintenance and operation.

Robust all-welded steel construction.

Smooth quiet operation with hydraulic motor drive in place of complicated ram operated systems.

Large capacity hopper with low loading height.

Fast loading continuous or intermittent operation.

Designed for most popular makes of chassis.

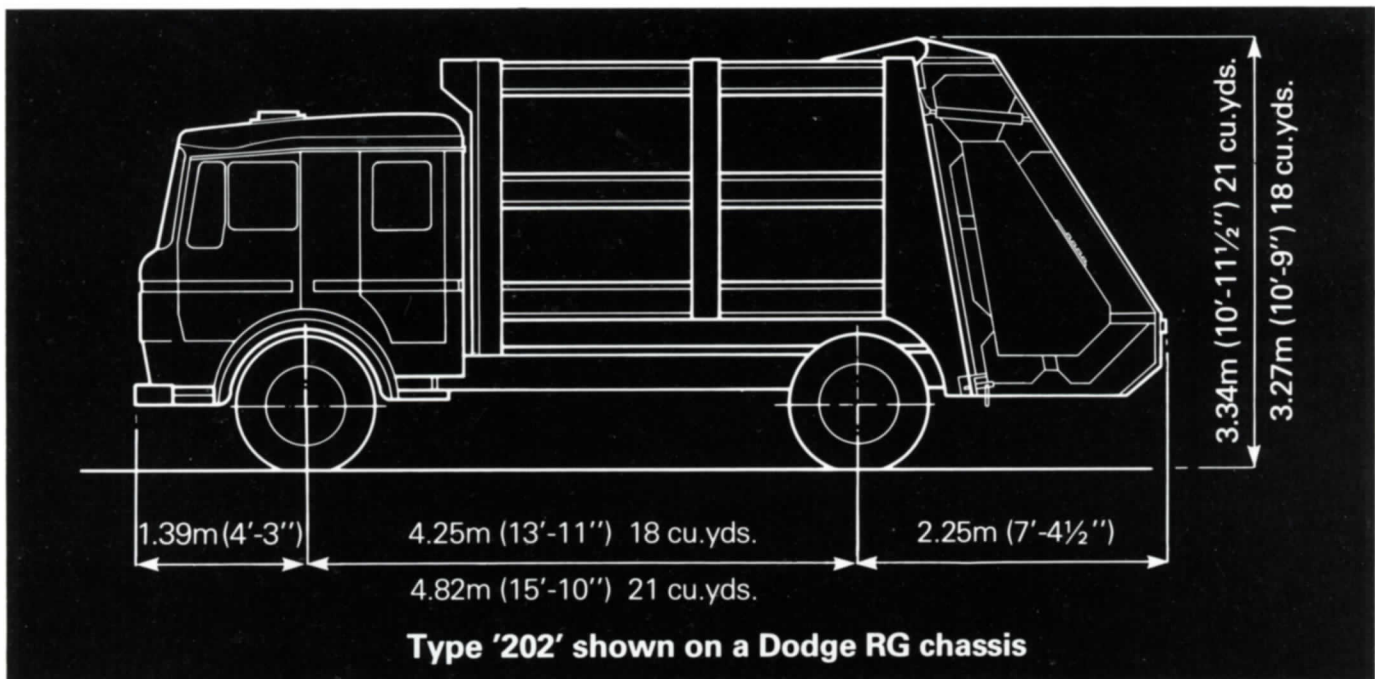

Specification

Body and Hopper Construction

All-welded steel with high wear resistant floor sweep plate and other wearing areas.

Packer Mechanism

Heavy duty packer plate carried on crank assemblies with pivoting top links and driven through roller chains by hydraulic motor and epicyclic reduction gear box. Hopper fitted with robust top hinges and lifted by single acting rams with safety check valves. Manual locks secure hopper to body during loading.

Hydraulic System

Large capacity hydraulic tank at front of body with suction filter and engine driven gear type hydraulic pump protected by a full-flow relief valve incorporating a dump valve to pass oil back to tank when hydraulic services are not required. Separate control valves for operating hydraulic motor packer drive, discharge barrier and hopper lift.

Controls

Push-buttons on loading hopper for start, stop and reverse operation of packer mechanism and selector switch for continuous or intermittent operation. Controls in cab include hand throttle, control for engaging pump operation and remote controls for hopper lift and discharge barrier.

Safety Features

Full width emergency stop bar on loading hopper – Rubber curtains in hopper and across lower edge of packer plate – Ejection barrier static until hopper raised – Hopper is self clearing when raised – Discharge barrier returns under refuse pressure only – Packer automatically cancels when P.T.O. disengaged – Warning light in cab when packer selected – Signal buzzer in cab operated by push button at loading point – Hopper lift safeguarded by hose failure valves

Optional Safety Features

P.T.O. disengagement on handbrake release – Reversing bleeper signal – Low level hydraulic tank filler connection, automatic hopper locks.

GENERAL DATA

Body Capacity	: 13.76 cu.m. (18 cu.yds.) or 16.05 cu.m. (21 cu.yds.)
Overall Height	: 3.27 m. 10'9" (18 cu.yds.) or 3.34m. 10'11 1/2" (21 cu.yds.)
Overall Width	: 2.44 m. (8'0")
Hopper Capacity	: Approx. 1.15 cu.m. (1.5 cu.yds.)
Hopper Width (inside)	: 1.85 m. (7'3")
Loading Height (unladen)	: 1.20 m. (4'7") (approx.)
Compaction Ratio	: 4 to 1 for average loads (approx.)
Packer Rate	: Up to 4 cycles / min. (continuous)

Glover Webb & Liversidge Limited Municipal Vehicles

**Sales & Service
Home & Overseas**
9/4/80

"A MEMBER OF THE COALITE GROUP"

Hamble Lane, Hamble, Hampshire, SO3 5NY.
Telephone: 042-122-2811 Telex: 477527