

GarWood SPECIFICATIONS

for

LOAD-PACKER®

SERIES

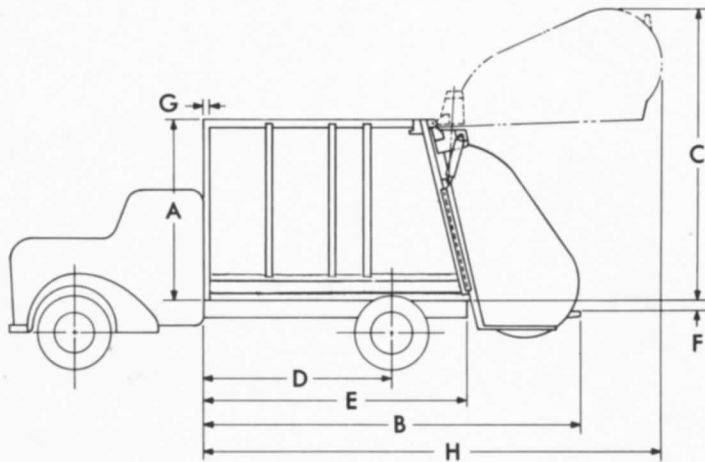

LP 716



LP 718



LP 720



LP 725

FEATURES

Fastest Operation—10 second cycle—4 second reloading time—less fuel consumption—10 second cycle means engine operates at high RPM less often.

Large Legal Payload—Less dead weight—better weight distribution.

Totally Enclosed Body—Leak proof—odor proof—spill proof.

Ejection Panel—Bulldozer shaped, clear of any projections for faster more complete cleanout and better packing characteristics.

Job Proven Packing Mechanism—Faster operating dependable, safer, controllable.

Ejection Cylinder—Double acting telescopic for both ejection and compaction—Gar Wood designed for long life, less maintenance.

Curb Side Loading Door—Standard on all sizes.

MODEL	CAPACITY	D										OVERALL UNIT	
		A	B	C	SINGLE	TANDEM	E	F	G	H	WIDTH	WEIGHT	
LP 716	16 CU. YDS.	94	185	145 $\frac{3}{8}$	102	84	132 $\frac{1}{2}$	4 $\frac{1}{2}$	1 $\frac{1}{2}$	232	95 $\frac{1}{2}$	9230	
LP 718	18 CU. YDS.	94	203	145 $\frac{3}{8}$	120	102	150 $\frac{1}{2}$	4 $\frac{1}{2}$	1 $\frac{1}{2}$	250	95 $\frac{1}{2}$	9480	
LP 720	20 CU. YDS.	94	218	145 $\frac{3}{8}$	135	120	165 $\frac{1}{2}$	4 $\frac{1}{2}$	1 $\frac{1}{2}$	265	95 $\frac{1}{2}$	9790	
LP 725	25 CU. YDS.	94	252	145 $\frac{3}{8}$	169	151*	199 $\frac{1}{2}$	4 $\frac{1}{2}$	1 $\frac{1}{2}$	299	95 $\frac{1}{2}$	10,300	

*Can be mounted on shorter CT depending on state weight restrictions and load density. Contact factory for recommendation.

GarWood INDUSTRIES, INC.
WAYNE, MICHIGAN • RICHMOND, CALIFORNIA

GarWood - LOS ANGELES
Truck Equipment, Inc.

4515 S. SOTO STREET VERNON, CALIF. 90058
Telephone: AREA CODE 213 / 583-3211