

# GarWood

# LOAD-PACKER

# 800 SERIES



## CHECK THESE FEATURES

1. Big 2-Yard Plus Hopper
2. Full Packing Panel Maneuverability
3. New Tremendous Crushing Power
4. Faster, Safer Operation
5. 3-Way Better Compaction
6. Improved Weight Distribution
7. Greater Strength-to-Weight Ratio
8. Faster, Cleaner Ejection
9. Superior Hydraulics
10. Fully Enclosed

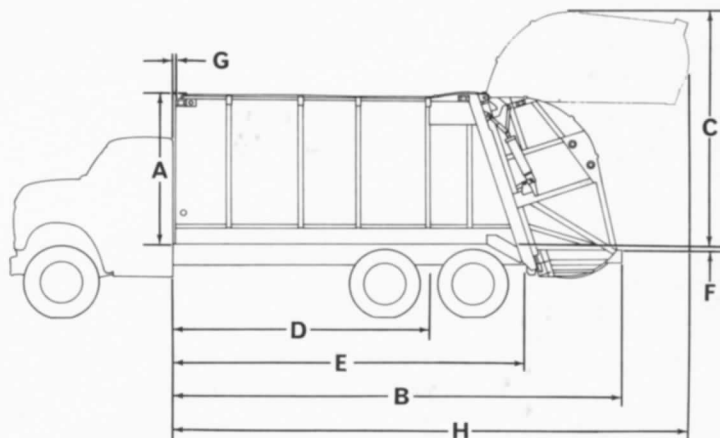

## SPECIFICATIONS

MODEL	CAPACITY	D									OVERALL WIDTH	UNIT WEIGHT
		A*	B	C*	SINGLE	TANDEM	E	F*	G	H		
LP820	20 CU YDS	90¼	224	142	135	120	159	1¼	1½	252	96	10390
LP825	25 CU YDS	90¼	258	142	169	**151	193	1¼	1½	286	96	10900

\*Unit can be mounted 2" lower depending on tire clearance.

\*\*Can be mounted on shorter CT depending on state weight restrictions and load density. Contact factory for recommendations.

## GarWood INDUSTRIES, INC.

WAYNE, MICHIGAN • RICHMOND, CALIFORNIA