

GarWood

LOAD-PACKER®

MOUNTED ON REO model WF475 CHASSIS

LP-725 25 cu. yds.

FEATURES

Fastest Operation—10 second cycle—4 second reloading time—less fuel consumption—10 second cycle means engine operates at high RPM less often.

Large Legal Payload—Less dead weight—better weight distribution.

Totally Enclosed Body—Leak proof—odor proof—spill proof.

Ejection Panel—Bulldozer shaped, clear of any projections for faster more complete cleanout and better packing characteristics.

Job Proven Packing Mechanism—Faster operating dependable, safer, controllable.

Ejection Cylinder—Double acting telescopic for both ejection and compaction—Gar Wood designed for long life, less maintenance.

Curb Side Loading Door—Standard on all sizes.

SPECIFICATIONS



WEIGHT DISTRIBUTION Based on 640 lbs. per yard

	FRONT	REAR	TOTAL
CHASSIS	7,770	1,580	9,350
BODY	2,850	7,120	9,970
PAYLOAD	6,750	9,250	16,000*
TOTAL	17,370	17,950	35,320

*Based on 18,000 lb. allowable legal axle load

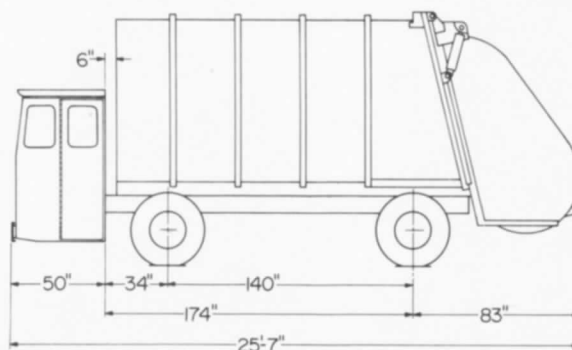

GarWood INDUSTRIES, INC.
WAYNE, MICHIGAN • RICHMOND, CALIFORNIA

Classic Refuse Trucks Library; www.classicrefusetrucks.com