

HOBBS HYD-PAK REAR LOADER

HRL SERIES REFUSE COLLECTION BODIES



HOBBS
HYD-PAK

HARRY K. SHEPARD, INC.
37½ CHESTER ROAD
SPRINGFIELD, VERMONT 05156
TEL. 885-2361

Manufactured By HOBBS TRAILERS
609 North Main, Fort Worth, Texas
a division of Fruehauf Corporation

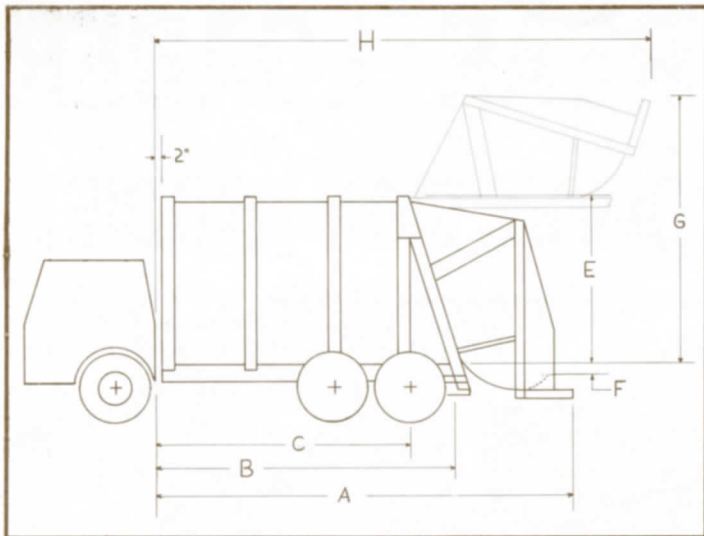

DIM	DESCRIPTION	CAPACITY		
		18 Cu.Yds	20 Cu.Yds	25 Cu.Yds
A	Length, cab to end of loader (min.)	210-3/4"	223-3/4"	256-3/4"
B	Length, cab to end of frame (max.)	147"	160"	193"
C	Cab to axle, single axle truck (min.)	102"	120"	
C	Cab to C/L rear axle, tandem axle truck (min.)		120"	145"
E	Max. height above truck frame	89-3/4"	89-3/4"	89-3/4"
F	Loading height below truck frame	6"	6"	6"
G	Height of raised loader above truck frame	145"	145"	145"
H	Cab to rear, loader raised	263"	276"	309"

Specifications HRL Series

BODY MODEL	HRL 18	HRL 20	HRL 25
BODY CAPACITY - Cubic Yards	18	20	25
LOADING HOPPER: Capacity - Cubic Yards Opening Width - Inches Opening Height - Inches	1-3/4 79-1/2 72	1-3/4 79-1/2 72	1-3/4 79-1/2 72
LOADING HEIGHT: Below Truck Frame - Inches	6"	6"	6"
INSIDE DIMENSIONS - BODY: Width - Inches Height - Inches Length - Inches	89-1/4 81 147	89-1/4 81 160	89-1/4 81 193
OVERALL DIMENSIONS: Width - Inches Height Above Truck Frame - Inches Length - Inches	95-1/2 89-3/4 208-3/4	95-1/2 89-3/4 221-3/4	95-1/2 89-3/4 254-3/4
PACKING FORCE: Lbs./Sq. Ft. - On Packing Plate Total Force - Packer Plate - Lbs.	5,023 83,382	5,023 83,382	5,023 83,382
PACKING CYCLE TIME - (Sec.)	17	17	17
EJECTION CYCLE TIME - (Sec.)	20	22	30
BODY WEIGHT - Lbs.	9,000	9,500	10,000
RECOMMENDED CHASSIS - S.A.*	102" CA	120" CA	
RECOMMENDED CHASSIS - TANDEM*		120" CT	145" CT

*These are minimum dimensions.

PACKING CONTROLS -

In switch box located each side of tailgate. Single pushbutton switch initiates automatic packing cycle.

OPERATING PRESSURE -

2,000 p.s.i.