

2RII[®]

REAR LOADER



The Highest Compaction, Full-eject, Versatile Rear Loader

Built to Handle the Big Loads

When the industry thinks about the biggest, strongest, most productive rear loader ever made, the Leach 2RII is clearly top of the line. This rear loader features superior durability and structural strength to handle the heaviest loads. The large 3-cubic yard hopper handles both commercial and residential refuse with ease. Choose from 20- to 31-yard body sizes along with a wide range of optional accessories for any application.

Designed for Optimum Strength and Performance

- Exclusive Floor-Trough™ design strengthens entire body while providing a natural sump for liquid containment
- Body reinforcing channels are closer together at rear where compaction forces are greatest
- Efficient telescopic ejection system standard
- Exclusive Two-by-Two™ Leach paint process keeps trucks looking sharp year after year
- 1/4" 100,000 PSI abrasion-resistant steel hopper bottom
- Full exterior continuous body welds for greater strength

Built for Maintenance and Operating Efficiency

- Curbside dual-lever packing controls
- Low loading height for operator convenience
- Interchangeable packer and carrier cylinders
- Full range of optional container handling systems
- All lights sealed and grommet mounted; rear light panel and hopper utility lights standard; heat-shrink wire connections throughout
- Easily removable ejection panel shoes located front and rear of panel
- Meets ANSI Z-245.1 safety standards

LEACH[®]

2RII®

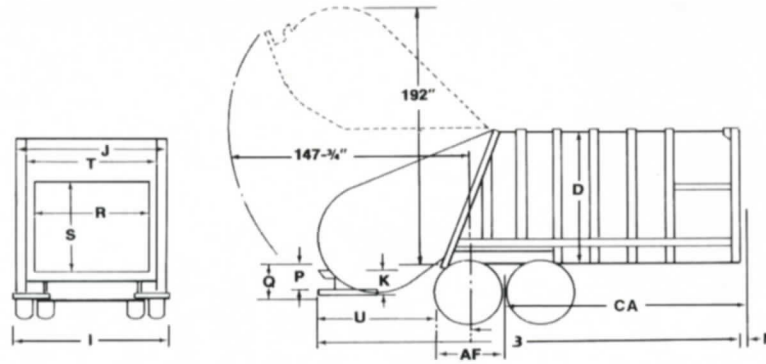

BODY DIMENSIONS	20 CU. YD.	25 CU. YD.	31 CU. YD.	15m ³	19m ³	24m ³
AF After Frame (52" Beam)	50"	50"	50"	1270 mm	1270 mm	1270 mm
B Overall Length	249"	270"	316"	6325 mm	6858 mm	8026 mm
CA To Centerline of Trunion (Note 2)	123"	144"	190"	3124 mm	3658 mm	4826 mm
D Height Above Chassis Frame	97"	97"	97"	2464 mm	2464 mm	2464 mm
I Body -- Outside Width	96"	96"	96"	2439 mm	2439 mm	2439 mm
J Body -- Inside Width	90"	90"	90"	2286 mm	2286 mm	2286 mm
K Hopper Depth	17"	17"	17"	432 mm	432 mm	432 mm
N Interference Point Above Chassis Frame	4"	4"	4"	102 mm	102 mm	102 mm
P Top of Step Below Chassis Frame	19"	19"	19"	483 mm	483 mm	483 mm
Q Hopper Bottom Below Chassis Frame	22"	22"	22"	559 mm	559 mm	559 mm
R Hopper Opening Width	80"	80"	80"	2032 mm	2032 mm	2032 mm
S Hopper Opening Height	56"	56"	56"	1423 mm	1423 mm	1423 mm
T Hopper Inside Width	80"	80"	80"	2032 mm	2032 mm	2032 mm
U Rear of Body to Rear of Tailgate Closed	74"	74"	74"	1880 mm	1880 mm	1880 mm
• Height Above Chassis Frame (Tailgate Raised)	194"	194"	194"	4928 mm	4928 mm	4928 mm
• Loading Sill Below Chassis Frame (Non Tag Axle Body)	5"	5"	5"	127 mm	127 mm	127 mm
• Center of Gravity Measured From Front of Body						
-Body Only	117"	131"	151"	2972 mm	3328 mm	3836 mm
-Pay Load	94"	103"	120"	2388 mm	2617 mm	3048 mm
• Hopper Capacity (volumetric)	3.0 cu. yd.	3.0 cu. yds.	3.0 cu. yd.	2.3 m ³	2.3 m ³	2.3 m ³
• Approx. Body Weight	14,495 lbs.	15,020 lbs.	16,125 lbs.	6575 kg	6813 kg	7314 kg
• Min. Truck GVWR Requirement (Note 1)	46,000 lbs.	52,000 lbs.	60,000 lbs.	20,862 kg	23,583 kg	27,211 kg

- Notes: 1. Truck selected must be capable of carrying net weight of body plus weight of refuse to be collected.
2. CA must be usable with no obstructions protruding above frame.

Features

- Sides, front and rear reinforced with electrically welded box sections and channels.
- Contents of body sealed off from outside during compaction cycle.
- Steps and grab handles both sides of tailgate.
- Buzzer system provided both sides at rear to enable loaders to signal driver.
- Load is ejected by simple, easily maintained, double-acting cylinder.
- Dual-lever packing controls at rear of hopper ... curbside.
- Single-lever ejection control at front of body ... street side.
- Single-lever tailgate lift control at front of body ... street side.
- Leach exclusive Two-by-Two™ Paint Process. White standard. Other colors optional. (Other colors may affect visibility.)
- Meets all ANSI Z-245.1 Safety Standards.

Due to our constant effort to offer the finest products available, we must reserve the right to change specifications without notice and without obligation to install them on units sold. Illustrations shown may include optional equipment and accessories, and may not include all standard equipment.

Hydraulic System

- Cylinders
 - (2) 6" double-acting packer plate cylinders*
 - (2) 6" double-acting carrier plate cylinders*
 - (1) Three (3) stage, double-acting ejection cylinder on 20 and 25 cu. yd. bodies
 - (1) Four (4) stage, double-acting ejection cylinder on 31" cu. yd. bodies
 - (2) 4" single-acting tailgate lift cylinders
- Packer and carrier plate cylinders are fully interchangeable, an exclusive with the 2RII.
- Pump
 - Leach -- gear type pressure compensating Capacity -- 42 GPM @ 1,200 RPM
- Maximum Operating Pressure -- 1950 PSI
- Hydraulic Tank
 - Capacity -- 45 gallons
 - Location -- Right-hand front on floor inside body
 - Filters -- 141 micron in-line suction strainer with by-pass valve
 - 10 micron return line filter with by-pass valve
- Sight gauge -- located on tank at eye level

Body Construction

- Sides -- 11 gauge Hi-Tensile, 50,000 PSI, 80,000 PSI
- Top -- 11 gauge Hi-Tensile, 50,000 PSI, 80,000 PSI
- Floor -- 11 gauge 80,000 PSI
- Floor-Trough -- 5/16" 50,000 PSI

Tailgate Construction

- Hopper sides -- 1/4" 50,000 PSI
- Hopper bottom -- 1/4" 100,000 PSI
- Packer and carrier plates -- 3/16" 50,000 PSI Packer Face 1/4" 80,000 PSI
- Top Sheet -- Secured with fasteners ... easily removed for maintenance

Optional Equipment

- Container handling
- Cart tipper (S)
- Lighting packages
- Commercial application packages
- Demolition debris application packages
- Many others available upon request

LEACH®

www.LeachUSA.com

Leach Company
2737 Harrison Street
P.O. Box 2608
Oshkosh, WI 54903
Telephone (920) 231-2770
Fax (920) 231-2712

International Distribution:
EL Industries International, Inc.
P.O. Box 645 • Barrington, IL 60011, U.S.A.
Telephone: (847) 382-0004 • Fax: (847) 382-0053