

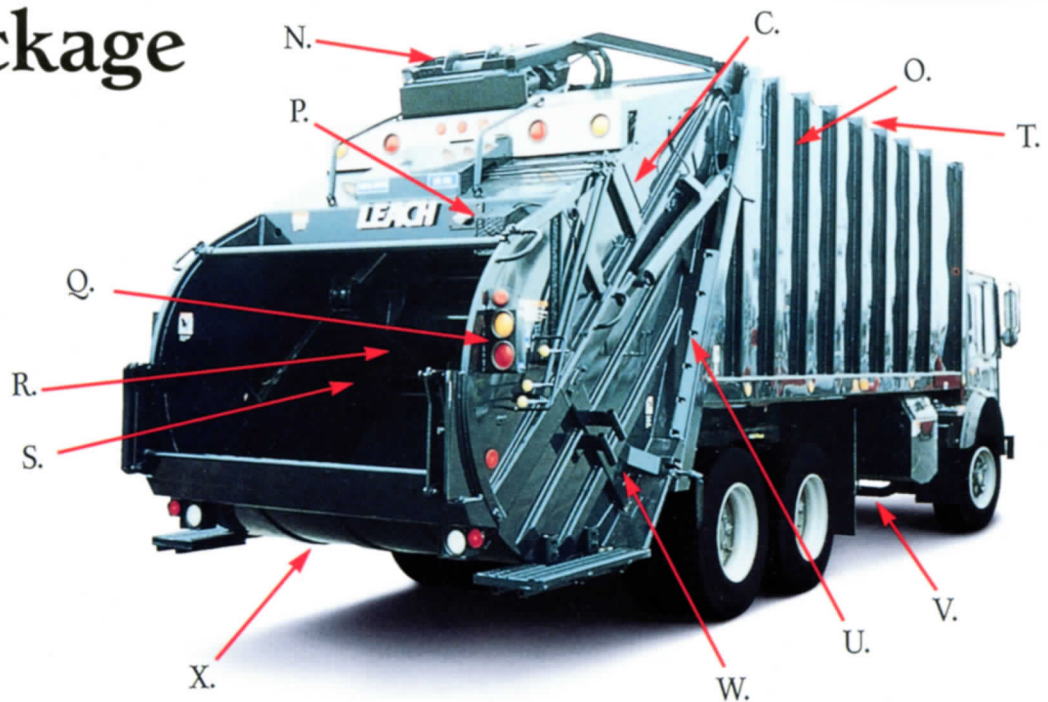

## 2RII<sup>HIP</sup> H.D. Package

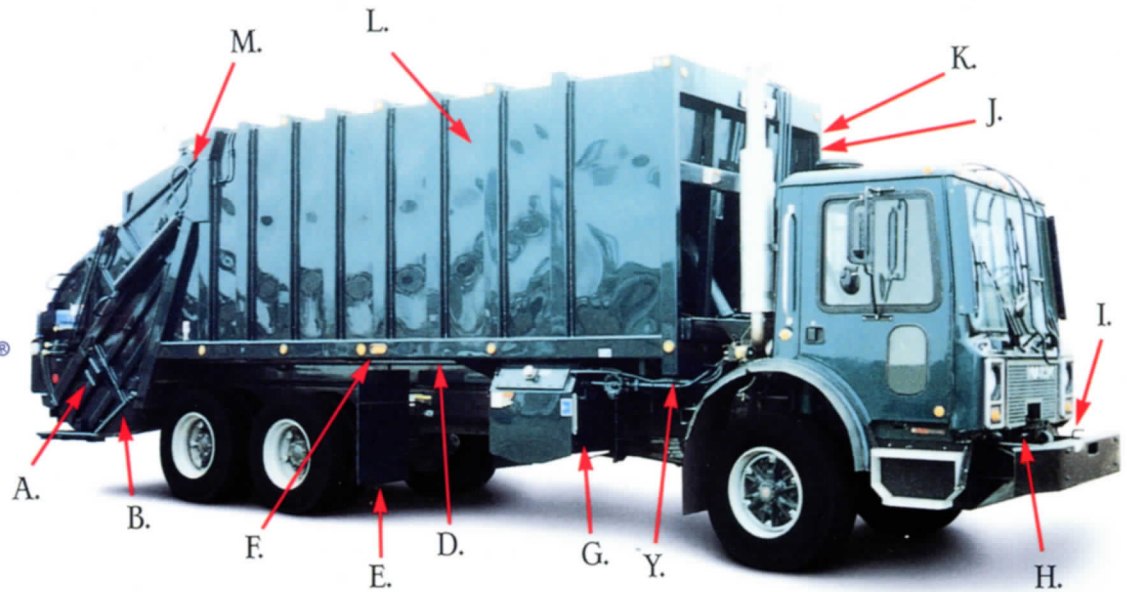

- A. Broom & Shovel Holder
- B. 1/4" Apron (Ramp) Liner
- C. Extra Channel Reinforcement
- D. One Piece 1/4 Floor Sheets
- E. Metal Mud Guards
- F. Mid-Body Turn Signals
- G. Underslung Hydraulic Reservoir
- H. H.D. Drive Shaft
- I. Muncie Front Mount Dry-Valve Pump
- J. H.D. Front Tube Support
- K. Locking Tabs on Tube Supports
- L. Diamond Force Ejection Panel 3/16" 80,000 PSI
- M. Low Profile Tailgate Lift Hose Routing

- N. 15,000# Drum Winch
- O. Rear 1/3 of Body Sides have Inside 1/8" Liner Reinforcement
- P. 5" Hopper Light with Guard
- Q. All Lights Sealed & Grommet Mounted
- R. Full Center Bearings between Packer & Carrier
- S. H.D. Packer Plate
- T. Extra Side Marker Lights
- U. Extended Tailgate Seal
- V. Dual Front Spring Mounts
- W. Side Sheet Liner Extra 1/8" Total 3/8"
- X. One Piece 1/2" Hopper Bottom - 100,000 PSI with Full Weld Braces
- Y. Front Spill Shield 6" Extension

# LEACH

## 2RII<sup>HIP</sup>

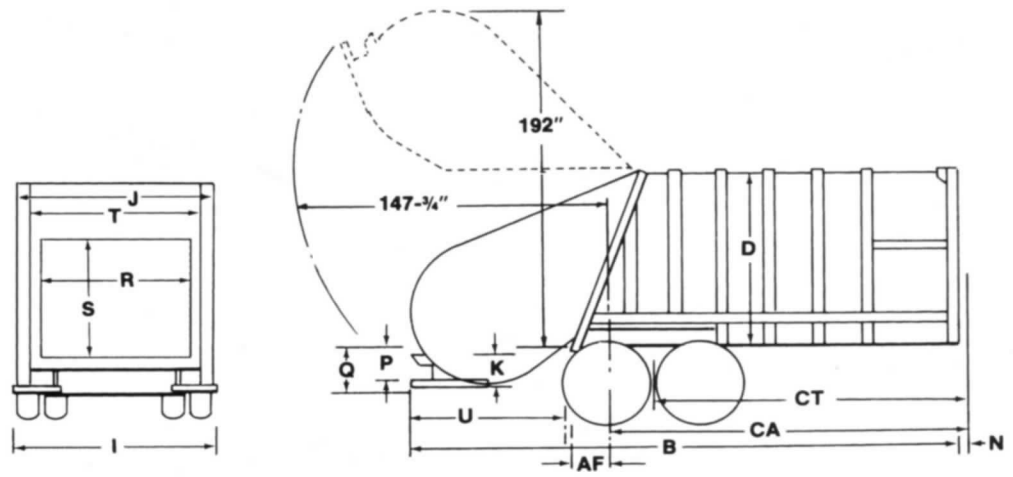

BODY DIMENSIONS	20 CU. YD.	25 CU. YD.	31 CU. YD.	15m <sup>3</sup>	19m <sup>3</sup>	24m <sup>3</sup>
AF After Frame	24"	24"	24"	610 mm	610 mm	610 mm
B Overall Length	249"	270"	316"	6325 mm	6858 mm	8026 mm
CA To Centerline of Rear Axle	150"	171"	217"	3810 mm	4343 mm	5512 mm
CT To Centerline of Trunion (52" Beam)	124"	145"	191"	3150 mm	3683 mm	4851 mm
D Height Above Chassis Frame	97"	97"	97"	2464 mm	2464 mm	2464 mm
I Body -- Outside Width	96"	96"	96"	2439 mm	2439 mm	2439 mm
J Body -- Inside Width	90"	90"	90"	2286 mm	2286 mm	2286 mm
K Hopper Depth	17"	17"	17"	432 mm	432 mm	432 mm
N Interference Point Above Chassis Frame	4"	4"	4"	102 mm	102 mm	102 mm
P Top of Step Below Chassis Frame	19"	19"	19"	483 mm	483 mm	483 mm
Q Hopper Bottom Below Chassis Frame	22"	22"	22"	559 mm	559 mm	559 mm
R Hopper Opening Width	80"	80"	80"	2032 mm	2032 mm	2032 mm
S Hopper Opening Height	56"	56"	56"	1423 mm	1423 mm	1423 mm
T Hopper Inside Width	80"	80"	80"	2032 mm	2032 mm	2032 mm
U Rear of Body to Rear of Tailgate Closed	74"	74"	74"	1880 mm	1880 mm	1880 mm
• Height Above Chassis Frame (Tailgate Raised)	194"	194"	194"	4928 mm	4928 mm	4928 mm
• Loading Sill Below Chassis Frame	5"	5"	5"	127 mm	127 mm	127 mm
• Center of Gravity Measured From Front of Body						
-Body Only	117"	131"	151"	2972 mm	3328 mm	3836 mm
-Pay Load	94"	103"	120"	2388 mm	2617 mm	3048 mm
• Hopper Capacity (volumetric)	3.0 cu. yd.	3.0 cu. yd.	3.0 cu. yd.	2.3m <sup>3</sup>	2.3m <sup>3</sup>	2.3m <sup>3</sup>
• Approx. Body Weight	14,495 lbs.	15,020 lbs.	16,125 lbs.	6575 kg	6813 kg	7314 kg
• Min. Truck GVWR Requirement	46,000 lbs.	52,000 lbs.	60,000 lbs.	21000 kg	24000 kg	28000 kg

Notes: \*Truck selected must be capable of carrying net weight of body plus weight of refuse to be collected.  
\*CA must be usable with no obstructions protruding above frame.

### Features

- Sides, front and rear reinforced with electrically welded box sections and channels.
- Contents of body sealed off from outside during compaction period.
- Steps and grab handles both sides of tailgate.
- Buzzer system provided both sides at rear to enable loaders to signal driver.
- Load is ejected by simple, easily maintained, double-acting cylinder.
- Dual-lever packing controls at rear of hopper... curbside.
- Single-lever ejection control at front of body... street side.
- Single-lever tailgate lift control at front of body... street side.
- Leach exclusive Two-by-Two Paint Process. White standard. Other colors optional. (Other colors may affect visibility.)
- Meets all ANSI Safety Standards.

Due to our constant effort to offer the finest products available, we must reserve the right to change specifications without notice and without obligation to install them on units sold. Illustrations shown may include optional equipment and accessories, and may not include all standard equipment.

### Hydraulic System

- Cylinders
  - (2) 6" double-acting packer plate cylinders\*
  - (2) 6" double-acting carrier plate cylinders\*
  - (1) 6", 5", 4" double-acting ejection cylinder on 20 and 25 cu. yd. bodies
  - (1) 6", 5", 4", 3" double-acting ejection cylinder on 31 cu. yd. bodies
  - (2) 4" single-acting tailgate lift cylinders
- Packer and carrier plate cylinders are fully interchangeable...an exclusive with the 2-RII.
- Leach exclusive clamp ejection system available
- Pump
  - Leach -- gear type pressure compensating
  - Capacity -- 42 GPM @ 1200 RPM
  - Maximum operating pressure -- 1650 PSI
- Hydraulic Tank
  - Capacity -- 45 gallons
  - Location -- Right-hand front on floor inside body
  - Filters -- 141 micron in-line suction strainer with by-pass valve
  - 20 micron return line filter with by-pass valve
- Sight gauge -- located on tank at eye level

### Body Construction

- Sides -- 11 gauge Hi-Tensile, 50,000 PSI, 80,000 PSI
- Top -- 11 gauge Hi-Tensile, 50,000 PSI, 80,000 PSI
- Floor -- 11 gauge 80,000 PSI
- Floor - Trough -- 5/16" 50,000 PSI

### Tailgate Construction

- Hopper sides -- 1/4" 50,000 PSI
- Hopper bottom -- 1/4" 100,000 PSI
- Packer and carrier plates -- 3/16" 50,000 PSI, Packer Face 1/4" 80,000 PSI
- Top Sheet -- Secured with fasteners...easily removed for maintenance

### Optional Equipment

- Hydraulic container attachment
- 8,000 lb. bolt on overhead winch
- 12,000 lb. bolt on overhead winch
- 12,000 lb. container lifting cylinder

# LEACH

Website: [www.LeachUSA.com](http://www.LeachUSA.com)

Leach Company  
2737 Harrison Street  
P.O. Box 2608  
Oshkosh, WI 54903  
Telephone (920) 231-2770  
Fax (920) 231-2712

International Distribution:  
EL Industries International, Inc.  
P.O. Box 645 • Barrington, IL 60011, U.S.A.  
Telephone: (708) 382-0004 • Fax: (708) 382-0053