

# SPECIFICATIONS | LEACH STATIONARY PACKER 2-R MODELS

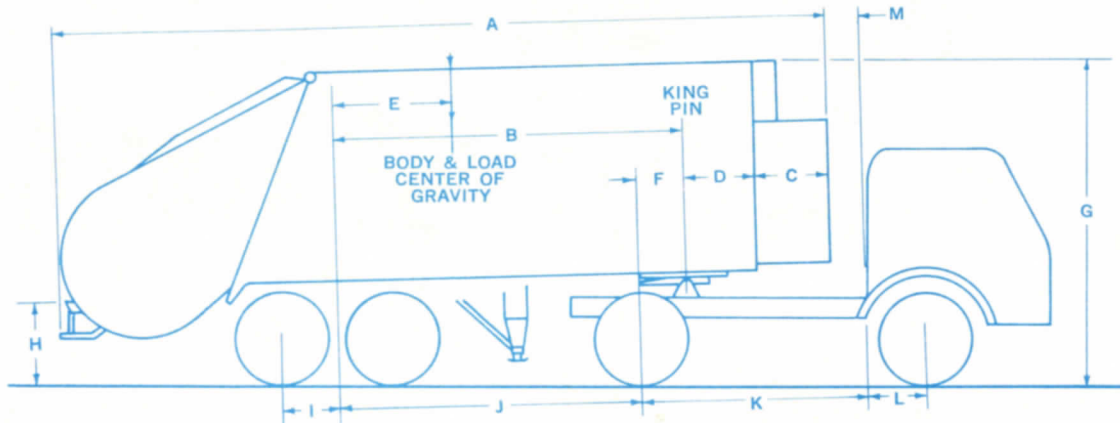

## DIMENSIONS: TRAILER

SIZE	A	B	C	D	E	F	G	H	I	J	K	L	M	
20 YD.	282 $\frac{3}{8}$	123 $\frac{1}{2}$	33	—	24.4	3	142	36 $\frac{1}{2}$	25 $\frac{1}{2}$	120 $\frac{1}{2}$	72	27	36	Provides 27" clearance when turning
25 YD.	303 $\frac{3}{8}$	121 $\frac{3}{4}$	33	22 $\frac{3}{4}$	31.4	3	142	36 $\frac{1}{2}$	25 $\frac{1}{2}$	118 $\frac{3}{4}$	72	27	13 $\frac{1}{4}$	Provides 7 $\frac{1}{2}$ " clearance when turning
31 YD.	349 $\frac{1}{2}$	158	33	32	53.3	21	142	36 $\frac{1}{2}$	25 $\frac{1}{2}$	137	102	27	16	Provides 11" clearance when turning

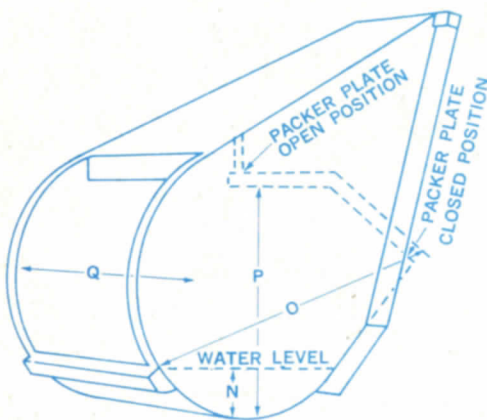

## DIMENSIONS: HOPPER

CAPACITY	N	O	P	Q
2 CU. YD.	16	82	56	80

## BODY

1. Sides and top are made of 11 gauge steel. Bottom is  $\frac{1}{4}$ " thick steel.
2. Sides, front and rear reinforced with electrically welded box-sections.
3. Contents of body sealed off from outside during compaction period.
4. Steps and grab handles both sides of tailgate.
5. Buzzer system provided at rear to enable loaders to signal driver.
6. Load is pushed out by simple, easily maintained double acting cylinder.

## POWER SOURCE

1. Truck Engine through P.T.O.
2. Gasoline Engine
3. Diesel Engine
4. Electrical Motor
5. Any combination of above four power sources

## TAILGATE

1. 2 cubic yard hopper capacity.
2. Entirely constructed of EX-TEN or equal alloy steel.
3. Packer and carrier plates constructed of  $\frac{3}{8}$ " thick EX-TEN steel.
4. Opens wide and stays clear of unloaded refuse when driving from unloading area.
5. Dual safety door can be operated automatically.
6. Single lever control.

## UNDERCARRIAGE (Trailer)

Includes axles, wheels (7.5 x 20 rims), 10:00 x 20, 12-Ply tires and tubes, Suspension System, Landing Gear and King Pin. 5th Wheel to be included as part of the Tractor Specification, and not part of the Undercarriage.

**FINISH:** Baked on enamel finish.

C. N. WOOD CO., INC.  
570 ARSENAL STREET  
WATERTOWN, MASS. 02172  
923-0200 — 923-0201

elgin

Sanitation is our only business

**ELGIN LEACH CORPORATION**

leach

SANITATION HEADQUARTERS

222 West Adams Street • Chicago, Illinois 60606

# SPECIFICATIONS

# LEACH STATIONARY PACKER STANDARD MODELS

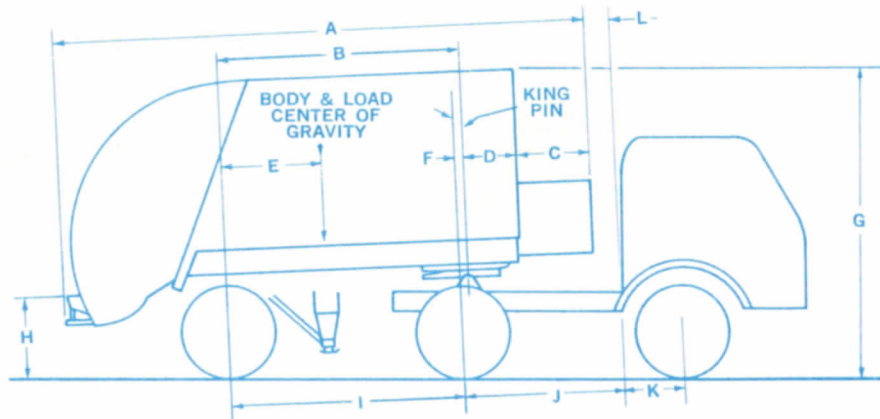

## DIMENSIONS: TRAILER

SIZE	A	B	C	D	E	F	G	H	I	J	K	L	
13 YD.	204 $\frac{3}{8}$	96 $\frac{1}{8}$	33	5 $\frac{1}{8}$	32	3	139	36	99	72	27	41 $\frac{3}{8}$	Provides 31" clearance when turning
16 YD.	227 $\frac{3}{8}$	102	33	17 $\frac{3}{8}$	41 $\frac{1}{2}$	3	139	36	99	72	27	18 $\frac{3}{8}$	Provides 12 $\frac{1}{2}$ " clearance when turning
17 YD.	240 $\frac{3}{8}$	108 $\frac{3}{8}$	33	24	45	3	139	36	105 $\frac{1}{8}$	72	27	12	Provides 6 $\frac{1}{2}$ " clearance when turning
20 YD.	255 $\frac{3}{8}$	123 $\frac{3}{8}$	33	24	53	3	139	36	120 $\frac{1}{8}$	72	27	12	Provides 6 $\frac{1}{2}$ " clearance when turning

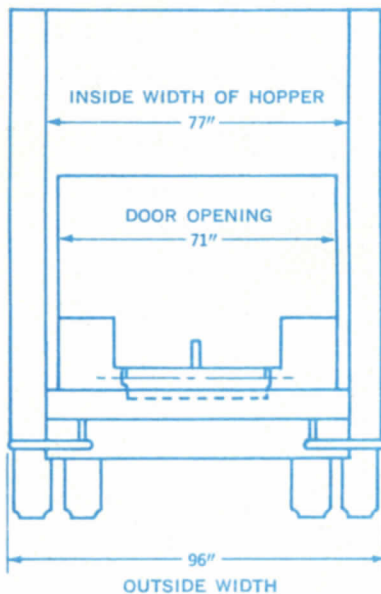

### BODY

1. Sides and top are made of 11 gauge steel. Bottom is  $\frac{1}{4}$ " thick steel.
2. Front and rear reinforced with electrically welded box section. Sides reinforced by 1" corrugations.
3. Contents of body sealed off from outside during compaction period.
4. Steps and grab handles both sides of tailgate.
5. Buzzer system provided at rear to enable loaders to signal driver.
6. Load is pushed out by simple, easily maintained double acting cylinder.

### POWER SOURCE

1. Truck Engine through P.T.O.
2. Gasoline Engine
3. Diesel Engine
4. Electrical Motor
5. Any combination of above four power sources

### TAILGATE

1. 1 $\frac{1}{4}$  cubic yard hopper capacity.
2. Constructed of EX-TEN or equal alloy steel.
3. Packer and carrier plates constructed of  $\frac{3}{8}$ " thick EX-TEN steel.
4. Opens wide and stays clear of unloaded refuse when driving from unloading area.
5. Dual door can be operated automatically.
6. Single lever control.

### UNDERCARRIAGE (Trailer)

Includes axles, wheels (7.5 x 20 rims), 10:00 x 20, 12-Ply tires and tubes, Suspension System, Landing Gear and King Pin. 5th Wheel to be included as part of the Tractor Specification, and not part of the Undercarriage.

**FINISH:** Baked on enamel finish.



Sanitation is our only business

**ELGIN LEACH CORPORATION**



SANITATION HEADQUARTERS

222 West Adams Street • Chicago, Illinois 60606