

LOAD-MASTER[®]

400 Series



The Ultimate Weapon

**Unequaled Excellence in
Design and Manufacture
In a Class of its own**

**Unsurpassed in Efficiency
and Productivity
Pride of the Industry**



400 Series Rear Loader

SPECIFICATIONS

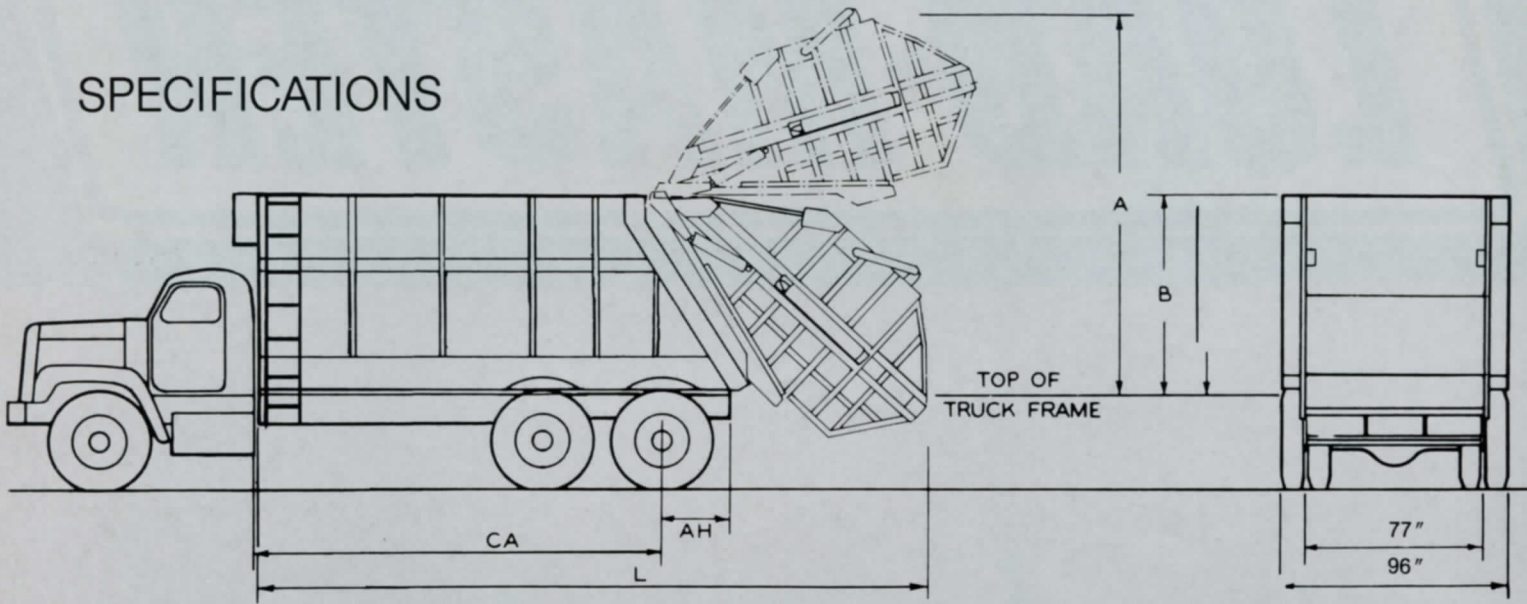

Dimensions

LOAD-MASTER MODEL	CAPACITY CU. YDS.	A INS.	B INS.	CA INS.	AH INS.	L INS.	WT. LBS. APPROX.	HOPPER CAPACITY CU. YDS. LOADED
LM-425	25	193	102	170*	25	266	17,400	2½
LM-431	31	193	102	204*	25	300	18,900	2½

*CA Dimension is to Center Line of Rear-most Axle

Container Handling Devices

The most efficient rear-loader container handling system available! Quick, smooth, positive, efficient —simple to maintain. Works totally independent of packing cycle. Single overhead double-acting hydraulic cylinder, with capabilities to fit your day-to-day needs. Model ranges as follows:

- Model 1-2 — 1 to 2 yard containers
- Model 2-6 — 2 to 6 yard containers
- Model 1-6 — The complete range

BASIC LOAD-MASTER LM-400 SERIES DATA

Body

Floor 11 gauge High Tensile
 Sides 11 gauge High Tensile
 Roof 11 gauge High Tensile

Tailgate

Hopper Floor 1/4" High Tensile
 Packing Plate 1/4" High Tensile
 Hopper Sides 11 ga. High Tensile
 Hopper Capacity 2½ cu. yds.

Hydraulic Systems

47 G.P.M. Gear Pump
 Multiple Balanced Spool-type valves
 with Adjustable Cartridge Relief

Note: Truck equipped with diesel engine requires variable speed governor.

Compare These Features with the Unit You're Now Using

Manufactured By:
 City Tank Corporation



Culpeper, Va.

A subsidiary of



Marketed Internationally By:



PHONE (904) 725-7214
 6501 ARLINGTON EXPRESSWAY, SUITE 103
 JACKSONVILLE, FLORIDA 32211

Distributed Locally By:

Casey & Dupuis Equipment Corp.
 340 Pleasant Street
 Watertown 72 - Mass.
 WA 4-7575

ClassicRefuseTrucks.com Library