

LOAD-MASTER[®]

100 High Compaction Series



Built to Challenge the Industry's Best

- Bigger Payloads
- Lowest Downtime in Industry
- Load-Master's Unsurpassed Reputation
- Larger Hopper - 2½ Cubic Yards
- Modern Cylinder-Type Container Hoist
- Built for Commercial & Residential Routes

SPECIFICATIONS

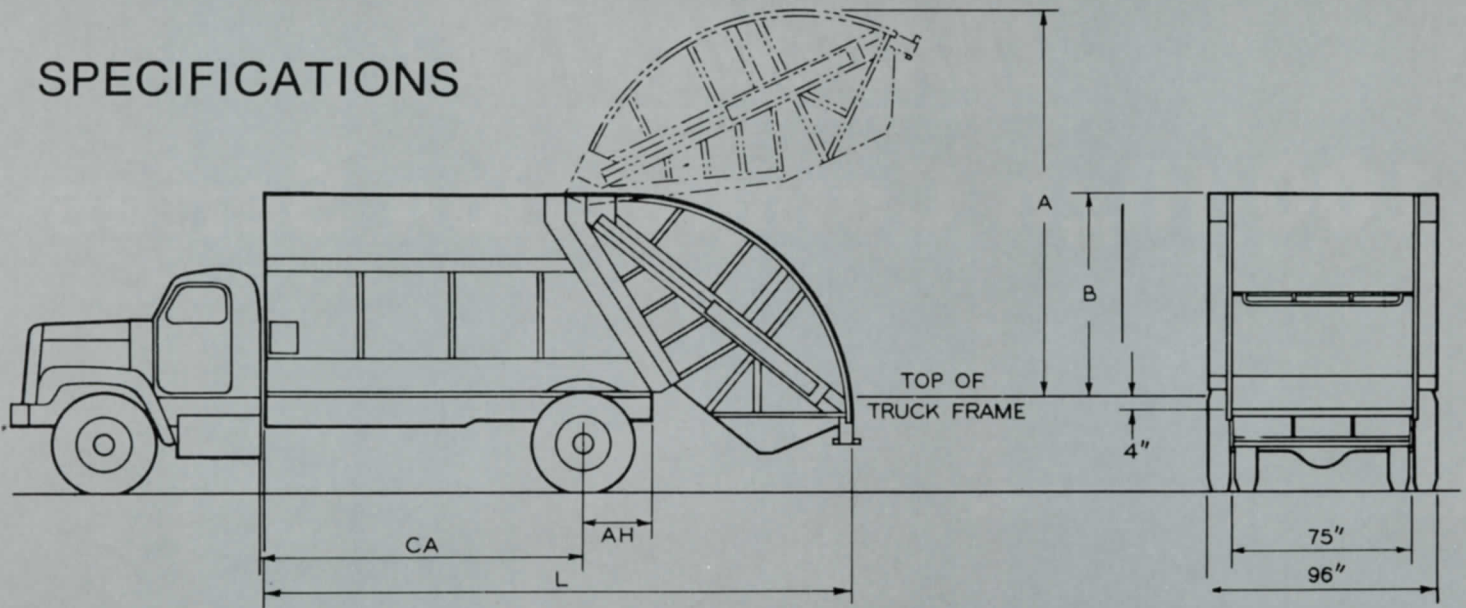

Dimensions

LOAD-MASTER MODEL	CAPACITY CU. YDS.	A INS.	B INS.	CA INS.	AH INS.	L INS.	WT. LBS. APPROX	HOPPER CAPACITY CU. YDS. LOADED
LM120HC	20	166	89	140	36	248	13,600	2½
LM120HCT	20	166	89	145*	26	248	13,600	2½
LM125HCT	25	166	89	169*	36	282	14,250	2½

*For Tandem Chassis CA Dimension is to Center Line of Rearmost Wheel

Container Handling Devices

The most efficient rear-loader container handling system available! Quick, smooth, positive, efficient — simple to maintain. Works totally independent of packing cycle. Single overhead double-acting hydraulic cylinder, with capabilities to fit your day-to-day needs. Model ranges as follows:

- Model 1-2 -1 to 2 yard containers
- Model 2-6 -2 to 6 yard containers
- Model 1-6 -The complete range

BASIC LOAD-MASTER LM-120 HC DATA

Body

Floor..... 11 gauge High Tensile
Sides 11 gauge High Tensile
Roof 12 gauge High Tensile
Understructure of Body—Full Width
Crossmembers Integral with Body
Floor

Tailgate

Hopper Floor 1/4" High Tensile
Packing Plate 1/4" High Tensile
Hopper Sides 3/16" High Tensile
Hopper Capacity 2 1/2 cu. yds.
Single Lever packing Controls

Hydraulic Systems

32 G.P.M. Gear Pump
Multiple Balanced Spool type valves
with Adjustable Cartridge Relief
All Cylinders—Chrome plated
Plunger Rods

Note: Truck equipped with diesel engine requires variable speed governor.

Compare These Features with the Unit You're Now Using



PHONE (904) 725-7214
6501 ARLINGTON EXPRESSWAY, SUITE 103
JACKSONVILLE, FLORIDA 32211

CASEY & DUPUIS EQUIPMENT CORP.
340 PLEASANT STREET
WATERTOWN, MASS. 02172
924-7575