

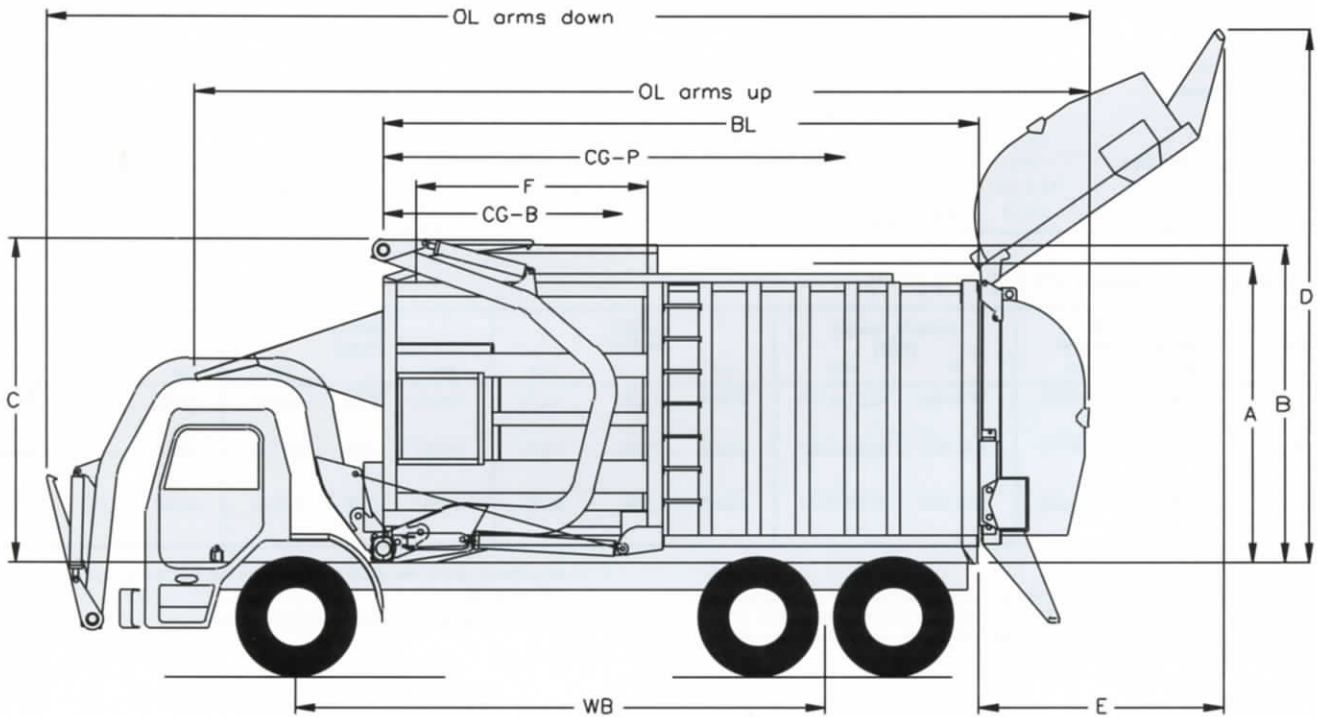

The high volume front loader that delivers higher net payloads with increased speed, reliability, and the proven performance of a Pak-Mor

FPE800 Pack/Eject Front Loader

PAK-MOR[®]
PAK-MOR[®]
PAK-MOR[®]



Dimensional Specifications

SYMBOL	DESCRIPTION	DIMENSIONS	
		in	mm
A	Body Height Without Windscreen	110	2794
B	Body Height Including Windscreen	118	2997
C	Body Height with Arms Up	119	3023
D	Height of Rear Door—Elevated Position	197	5004
E	End of Body to End of Rear Door—Elevated Position	91	2311
F	Hopper Opening Length	86	2184
-	Body Width Including Lift Arms	96	2438

The products illustrated in this catalog are protected by United States and foreign patents, patents pending, and patents applied for. Illustrations and specifications are not binding as detailed as Pak-Mor reserves the right under the company's product development program to change design or construction details and to furnish equipment when thus altered without reference to illustrations or specifications presented herein and supersede all previously published information.

1123 South East Military Drive
 San Antonio, Texas 78214
 U.S.A.

Post Office Box 14147
 San Antonio, Texas 78214
 U.S.A.

Telephone: (210) 923-4317
 Fax: (210) 922-7782

PAK-MOR[®]
PAK-MOR[®]
PAK-MOR[®]
 DOING A BETTER JOB THROUGH BETTER DESIGN

FPE800 Front Loader Specifications



General Specifications

CG = Center of Gravity

MODEL	CAPACITY		OVERALL LENGTH (OL - ARMS DOWN)		OVERALL LENGTH (OL - ARMS UP)		BODY LENGTH (BL)		CG - BODY (CG-B)		CG - PAYLOAD (CG-P)		BODY WEIGHT (approximate)	
	yd ³	m ³	in	mm	in	mm	in	mm	in	mm	in	mm	lbs	kgs
FPE830	30	22.9	372	9449	318	8077	208	5283	78	1981	150	3810	16700	7575
FPE836	36	27.5	384	9754	330	8382	220	5588	80	2032	155	3937	17260	7829
FPE840	40	30.6	432	10973	378	9601	268	6807	85	2159	170	4318	18500	8392

Body and Construction Specifications

80,000 PSI Steel § 100,000 PSI Steel † Hi-Tensile Steel

Body Sides [#]	11 ga	3.04 mm	Rear Door Lift Cylinders	3 in	76.20 mm	Packing Cycle	20 seconds (approx.)
Body Roof [#]	11 ga	3.04 mm	Packer Plate:			Lift Cycle	16 seconds (approx.)
Body Floor [†]	3/16 in	4.76 mm	Lower Face [†]	1/4 in	6.35 mm	Lift Capacity	8000 lbs 3629 kgs
Hopper Sides (upper) [†]	11 ga	3.04 mm	Upper Face [†]	10 ga	3.40 mm	Lift Cylinders	5 in 127.0 mm
Hopper Sides (lower) [†]	3/16 in	4.76 mm	Guides [§]	6 in	152.4 mm	Tilt Cylinders	4 in 101.6 mm
Hopper Floor [§]	1/4 in	6.35 mm	Packing Force:			Oil Reservoir	60 gal 227.1 lit
Top Hopper Cover [†]	14 ga	1.91 mm	Packer Cylinder Output	118790 lbs	53883 kgs	Pump	58 gpm 219.5 lpm
Top Hopper Door Cylinders	3 in	76.20 mm	Packer Face	16.5 psi	1.2 kgs/cm ²	Hoses	4-to-1 burst
Hopper Capacity	12.0 yd ³	9.2 m ³	Packer Face (lower only)	49.5 psi	3.5 kgs/cm ²	Primary Oper. Pressure	2500 psi 175.8kgs/cm ²
Rear Door [†]	10 ga	3.40 mm	Packer Cylinders (main bore)	5.5 in	139.7 mm	Body Taper	1 degree

Chassis Requirements (*) (**) (***) (****)

MODEL	CT "CLEAR" CAB-TO-TANDEM		WHEEL BASE (WB)		GAWR FRONT			GAWR REAR			GVW MINIMUM	
	in	mm	in	mm	lbs	COE	kgs	lbs	COE	kgs	lbs	kgs
FPE830	158-168	4013-4267	178-188	4521-4775	20000	COE	9072	40000	COE	18144	60000	COE 27216
FPE836	170-180	4318-4572	190-200	4826-5080	20000	COE	9072	40000	COE	18144	60000	COE 27216
FPE840	180-190	4572-4826	200-210	5080-5334	20000	COE	9072	44000	COE	19958	64000	COE 29030

(*) COE = Cab Over Engine

(**) Body weights, minimum front and rear gross axle weight ratings (GAWR), and gross vehicle weights (GVW) are for standard FPE800 bodies. If optional features are specified, GAWR and GVW must be increased accordingly. Consult factory for optimal wheelbase and axle weight distribution on specific chassis models.

(***) Any chassis sent to PAK-MOR MFG. CO. with less than the minimum specifications will not be mounted.

(****) Diesel engines require full variable speed governor.

Standard Equipment (except as may be replaced by optional equipment)

- Top hinged hydraulic rear door
- Automatic rear door locks
- Rear door maintenance props
- FMVSS #108 lights and reflectors
- High mounted tail and stop lamps
- Rear, center mounted stop light
- Mid-body marker/turn lights
- Vehicle conspicuity sheeting
- Warning alarm
- Sliding hydraulic top hopper cover — automatic open only
- Access door — with ladder, streetside only
- Body side ladder — streetside only
- Packer lock-out — to prevent container dumping behind packer plate
- 25 gal. sump with clean-out doors
- Hinged full cab cover — air cylinder, actuated with manual switch at front of body
- Cab controls — positive lever, cable actuated pack, rear door, top hopper cover, and lift controls
- Frame mounted oil reservoir — 60 gal. capacity, equipped with magnetic trap, oil level sight gauge, filler-breather cap, shut-off valve (suction line), and clean-out port
- Filters — 90 GPM dual spin-on element return line filter with visual indicator and 90 GPM dual element suction line filter
- FMCS Reg. 49 (CFR 393.86 rear underride guard)
- Splash guards

Optional Equipment

- Automatic pack
- Power take-off and live power drive options
- Tapered windscreen (12 inches high)
- Rear view camera/monitor options
- Air cab controls — positive lever, air actuated pack, rear door, top hopper cover controls, four-way joystick, and air actuated lift controls (chassis must have air supply)
- Container wash-out system — 80 gal. capacity, equipped with hand-held sprayer (chassis must have air supply)
- Aluminum one-piece fenders
- Synthetic two-piece fenders
- Tool box