

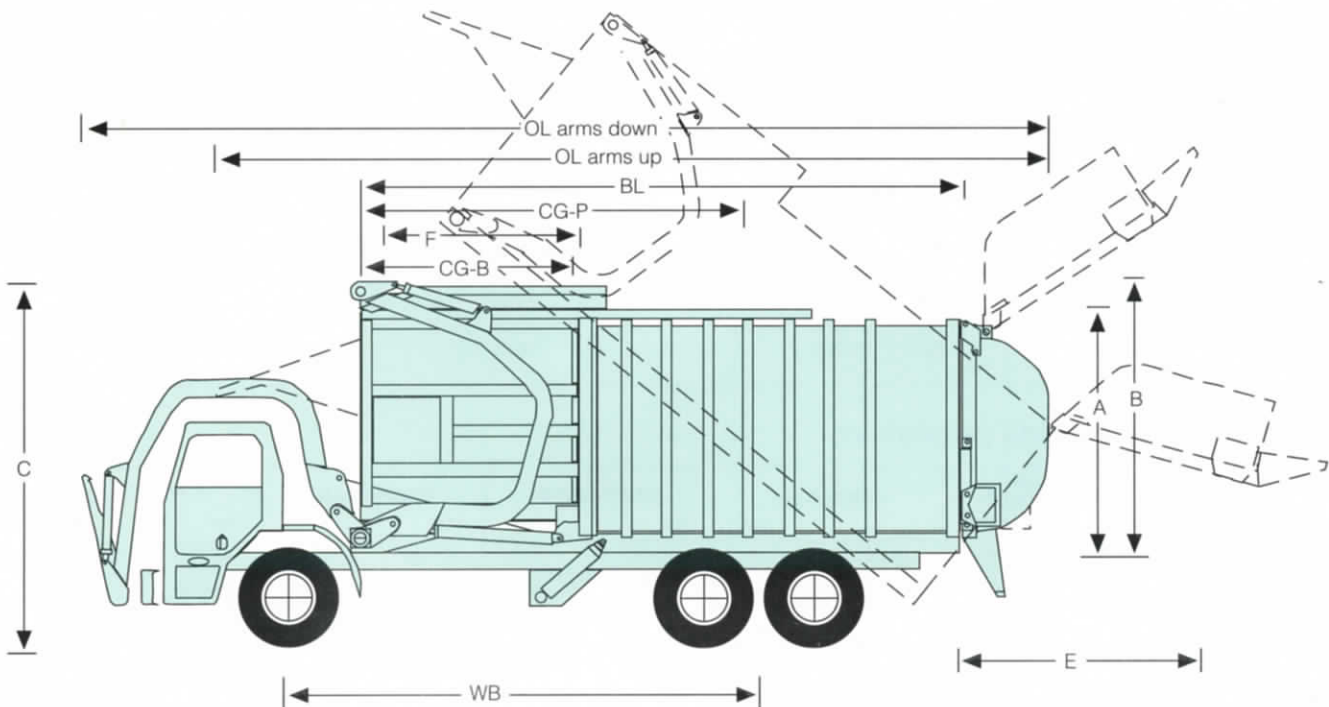

The lightweight, high volume front loader that delivers higher net payloads with increased speed, reliability and the proven performance of a Pak-Mor.

# FPD800L LIGHTWEIGHT Pack/Dump Front Loader

**PAK-MOR<sup>®</sup>**  
**PAK-MOR<sup>®</sup>**  
**PAK-MOR<sup>®</sup>**



## Dimensional Specifications

SYMBOL	DESCRIPTION	DIMENSIONS	
		in	mm
A	Body Height	110	2794
B	Body Height - With Optional Windscreen	118	2997
C	Body Height - With Arms Up	119	3023
D	Height of Rear Door - Elevated Position (FPD840L)	197	5004
D'	Height of Rear Door - Elevated Position (FPD835L)	157	3989
E	End of Body to End of Rear Door - Elevated Position (FPD840L)	91	2311
E'	End of Body to End of Rear Door - Elevated Position (FPD835L)	81	2057
F	Hopper Opening Length	86	2184
G	Body Height - Dump Position	245	6223
-	Body Width Including Lift Arms	96	2438

The products illustrated in this catalog are protected by United States and Foreign patents, patents pending and applied for. Illustrations and specifications are not binding as detailed as Pak-Mor reserves the right under the company's product development program to change design or construction details and to furnish equipment when thus altered without reference to illustrations or specifications presented herein, and supersedes all previously published information.

1123 S.E. Military Dr. P.O. Box 14147 San Antonio, Texas 78214  
 1-210-923-4317 FAX: 1-210-922-7782

Pak-Mor Worldwide, Inc. P.O. Box 79 9548 Matzingen, Switzerland  
 41-54-53.18.94 FAX: 41-54-53.14.27

**PAK-MOR<sup>®</sup>**  
**PAK-MOR<sup>®</sup>**  
**PAK-MOR<sup>®</sup>**  
 DOING A BETTER JOB THROUGH BETTER DESIGN

# FPD800L Front Loader Specifications.



## General Specifications

MODEL	CAPACITY		OL OVERALL LENGTH		OL OVERALL LENGTH		BL BODY LENGTH		CG-B BODY		CG-P PAYLOAD		BODY WEIGHT (Approx.)	
	yd <sup>3</sup>	m <sup>3</sup>	in	w/ arms dn mm	in	w/ arms up mm	in	mm	in	mm	in	mm	lbs	kgs
FPD835L	35	26.76	402	10,211	348	8839	268	6807	82	2083	155	3937	17,670	8015
FPD840L	40	30.58	432	10,922	378	9601	268	6807	85	2159	170	4318	17,970	8151

## Body and Construction Specifications

# 80,000 PSI Steel § 100,000 PSI Steel ‡ Hi-Tensile Steel

	in	mm		in	mm		in	mm
Hopper Sidewalls ‡ (upper)	12 GA	2.67	Hopper Capacity	12.0 yd <sup>3</sup>	9.2 m <sup>3</sup>	Rear Door Lift Cyls.	3	76.2
Hopper Sidewalls ‡ (lower)	10 GA	3.40	Lift Cycle	Approx. 16 seconds		Top Hopper Door Cyl.	3	76.2
Hopper Floor ‡	3/16	4.76	Lift Capacity	8000 lbs.	3629 kgs.	Dump Cyls.	6	152.4
Body Sidewalls#	12 GA	2.67	Pack Cycle	Approx. 20 seconds		Oil Reservoir	60 Gal.	227.1 Lit.
Body Floor ‡	10 GA	3.40	Packing Force			Pump	58 GPM	219.5 LPM
Body Roof #	12 GA	2.67	Packer Cyl. Output	113,097 lbs.	51,300 kgs.	Hoses	4 to 1 Burst	
Rear Door ‡	11 GA	3.05	Packer Face	15.7 PSI	108.3 KPA	Operating Pressure	2000 PSI	13,790 KPA
Top Hopper Cover ‡	14 GA	1.91	Packer Face (Lwr. Only)	47.1 PSI	324.7 KPA	Dumping Angle	35°	
Packer Plate ‡ (lower face)	1/4	6.35	Packer Cyls. (Main Bore)	6	152.4	Body Taper	1°	
Packer Plate ‡ (upper face)	10 GA	3.40	Lift Cyls.	5	127.0			
Packer Plate Guides §	6	152.4	Tilt Cyls.	4	101.6			

## Chassis Requirements (\*) (\*\*) (\*\*\*) (\*\*\*\*)

MODEL	CT "CLEAR" CAB-TO-TANDEM		WB WHEELBASE		GAWR-FRONT		GAWR-REAR		GVW-MINIMUM	
	in	mm	in	mm	lbs	kgs	lbs	kgs	lbs	kgs
FPD835L	171-181	4343-4597	191-201	4851-5105	20,000	9072	40,000	18,144	60,000	27,216
FPD840L	180-190	4572-4826	200-210	5080-5334	20,000	9072	44,000	19,958	64,000	29,030

(\*) Cab Over Engine

(\*\*) Body weights, minimum front and rear gross axle weight ratings (GAWR), and gross vehicle weights (GVW) are for standard FPD800L bodies. If optional features are specified GAWR's and GVW must be increased accordingly. Consult factory for optimal wheelbase and axle weight distribution on specific chassis models.

(\*\*\*) Any Chassis sent to PAK-MOR MFG. CO. with less than the minimum specifications will not be mounted.

(\*\*\*\*) Diesel engines require full variable speed governor.

## Standard Equipment (except as may be replaced by optional equipment)

- Top hinged hydraulic rear door
- Automatic rear door locks
- Sliding hydraulic top hopper cover — automatic open only
- Access door — with ladder, streetside only
- Body side ladder — streetside only
- 25 gal. sump with clean-out doors
- Hinged full cab cover — air cylinder actuated with manually actuated switch on front of body
- Warning alarm
- FMVSS #108 lights and reflectors
- Cab controls — positive lever, cable actuated pack, rear door, top hopper cover, dump, and lift controls
- Splash guards
- Frame mounted oil reservoir — 60 gal. capacity mounted on chassis frame. Equipped with magnetic trap, oil level sight gauge, filler-breather cap, shut-off valve (suction line), and clean-out port
- Filters — 90 GPM dual spin-on element return line filter with visual indicator. 90 GPM dual element suction line filter
- FMCS Reg. 49 (CFR 393.86) rear underride guard

## Optional Equipment

- Air cab controls — positive lever, air actuated pack, rear door, top hopper cover and dump controls. Four-way joystick, air actuated lift controls (chassis must have air supply)
- Automatic pack
- Packer lock-out — to prevent container dumping behind packer plate
- Power take-off and live power drive options
- Cab lid deflector options
- 12 inch height tapered windscreen
- Hopper floor wear strips
- Proximity alert back-up sensor
- Rear view camera/monitor options
- Container wash-out system — 80 gal. capacity. Equipped with hand-held sprayer (chassis must have air supply)
- Tool box
- Aluminum one-piece fenders
- Synthetic two-piece fenders

All PAK-MOR Bodies comply with standards established by the American National Standards Institute (ANSI Z 245.1-1992) FPD800L-930601