

MUNICIPAL VEHICLE range

from Shelvocke and Drewry Limited

Technical Data Sheet



Equipment Specification

(For full vehicle specification see NT Revopak Data Sheet)

Special purpose lifting equipment available
for fitment to Series 22 NT Revopak Refuse
Collection Vehicle

Hydraulic drive lifting winch for handling 8/10 cubic
yard capacity rectangular containers.

Model: NT series Revopak Bulk Loader System

Technical Data Sheet

Model: NT series Revopak Bulk Loader System

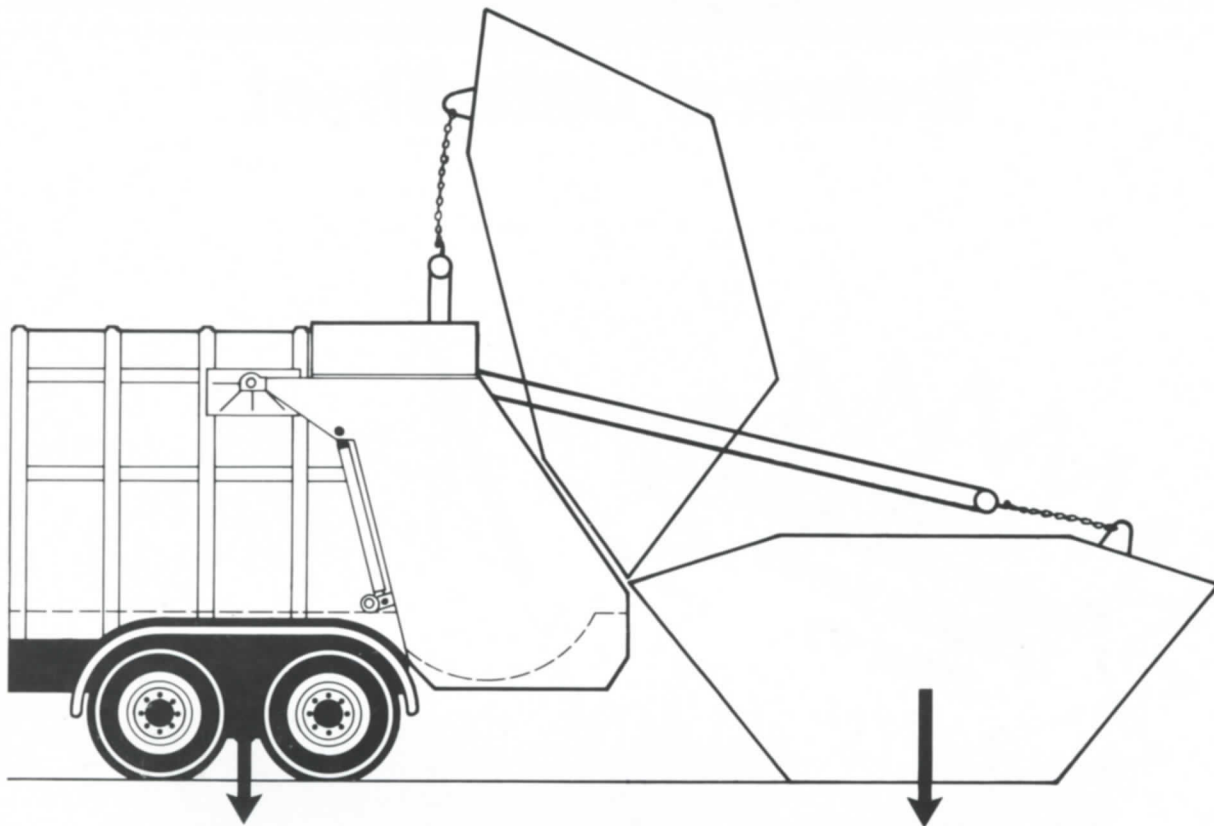

Technical Data

NT Revopak

Wheelbase
Overall length
Rave height
Overall height
Overall width
Body inside width
Body inside height
Body air space
Gross vehicle weight

14'6"
28'11"
4'4"
11'1"
8'0"
6'10"
6'8"
22 cu yds
22 tons

Lifting capacity

Maximum moment of container and load 105,000 lbs ft
EG load in container shown at centre of gravity = 6000 lbs.

Maximum dimensions of containers

Width 5'7"
Height 4'9½"
Length 14'6"

Lifting equipment

Winch pump 6 imp gpm at 1450 rpm
Winch model Boughton V H 6
Bare drum line pull 6750 lb
Pressure setting 1000 PSI
Line speed 15 ft/min average
Cycle time 90 seconds approx



MUNICIPAL
VEHICLE
range

Shelvoke and Drewry Limited, Municipal Vehicle Division
Icknield Way, Letchworth, Herts SG6 1EN, England
Telephone: Letchworth 6555 Telex: 825556

A Butterfield - Harvey Company Specifications subject to alterations without notice

Printed by Graphic Litho Limited/Welwyn Garden City/Hertfordshire

ClassicRefuseTrucks.com Library