

CARGOPAC

Millennium

*Designed
for the present and future.*

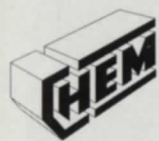

CARGOPAC

Compact and manoeuvrable **pivot link compaction for**



Pivot Link compaction

The three stage mechanism allows genuine continuous loading; creating maximum compaction at very low compression and guarantees the rectangular body space is totally filled giving even distribution of load carried. The Cargopac can be used as an intermittent loader equally as well.

Bin Lift

Any manufacturers bin lift can be fitted to the Cargopac. The vehicles are fitted with double pump, pipe work for hydraulics and electrics to the rear of the vehicle and already have a squared off hopper as standard.



The Range

Manufactured in three different heights and widths and nine lengths. Our equipment is adaptable to any type of chassis and can match your requirements perfectly.



Maintenance

Whith connecting rods and ball socket joints, the main features of, the pivot link mechanism, maintenance is made easy.

for today's congested cities **today's fast loading bin lifts.**



Technical Features

The short tailgate overhang reduces overall length and compliments the manoeuvrability of the vehicle.

Components

- *Choice of high quality steels depending on each function of the refuse vehicle.*
- *Body : CORTEN steel 3 and 4 mm.*
- *Body floor : FERALISM steel 3 and 4 mm.*
- *Hopper floor : CREUSABRO steel 6 mm.*
- *Entrance for the body : CREUSABRO steel 5 mm.*

Manufacture of the components

- *Computerised laser cut.*
- *Robotised welding of the body.*
- *Mechanical parts engineered in our own robotised production.*
- *Micron calculated precision.*
- *Assembling of the components with hydraulic machines.*

Anti-corrosion treatment

- *Indoor cleaning, grease removal and phosphatisation.*
- *Sizing with polyurethane.*
- *Paint : two crossed coats of polyurethane for a film of 100 microns, a one-hour exposure at 60° C. temperature.*

Maintenance made easy

- *Integrated in build*
- *Fully autolubed compaction system*
- *High and low pressure filtration to 6 microns*
- *Full diagnostic reader*

CARGOPAC

Tailgate Depth only 1465mm

Large

2.3 cu. metre hopper

- *Compression ratio :
Low pressure 4:1
High pressure 6:1*
- *Length of a compaction cycle :
18/20 sec.*
- *Noise level of the Compacting system :
The pivot link design, of connecting rods, the ball and socket joints and its progressive control method, reduces the noise level to only 75 dBA.*
- *Operation speed from 950 to 1200 t/npm depending on Engine revs.*

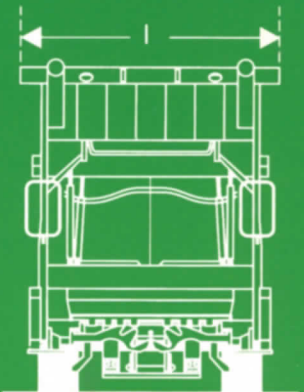

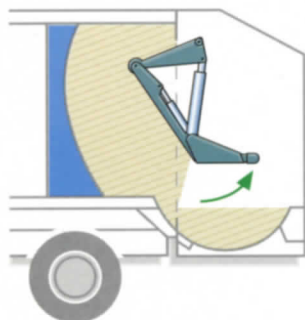

SEMAT
MUNICIPAL VEHICLE MANUFACTURERS

SEMAT CARGOPAC BODY OPTIONS...

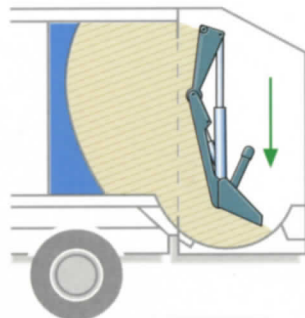

1 - Opening of the packer plate.



2 - Opening of the upper and lower panels

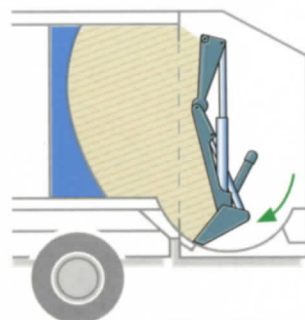

3 - Closing of the packer plate.

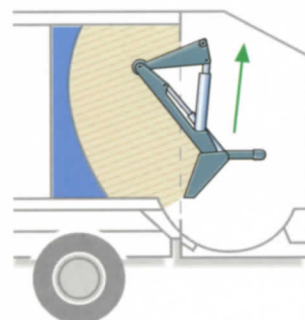

4 - Closing of the panels

Type	Approx volume	Optimum chassis GW	Width	Axles
110	7	From 10,000 kg	2100	4 x 2
112	8	to 12,000 kg	2100	4 x 2
212	10	From 14,000 kg	2360	4 x 2
213	11	to 16,000 kg	2360	4 x 2
224	13	17,000 kg	2360	4 x 2
225	14	19,000 kg	2360	4 x 2
229	18	23,300 kg	2360	6 x 2
334	15	From 18,000 kg	2490	4 x 2
335	16	to	2490	to
336	17,5	19,000 kg	2490	6 x 2
338	20,5	From 23,300 kg	2490	6 x 2
339	22	to 26,000 kg	2490	6 x 2/4



Municipal Equipment Sales & Hire

Lyons Lane - Chorley - Lancs PR7 3BL

Tél 01257-266228 - Fax 01257-261781

e-mail : 1@meshsales.co.uk - Internet : <http://www.meshsales.co.uk>