

# EXPRESS SERIES



- Superior unibody design incorporating convex curved body panels for enhanced strength to weight ratio
- Extra large hopper loading door
- Low liftover height
- Ultrawear® pack slides for superior wear resistance
- Adjustable multi-cycle automatic pack control

***“It’s like being served  
on a silver platter.”***

*George Seagull*



## Technical highlights

### APPROXIMATE WEIGHT\*

Body capacity (yd <sup>3</sup> )	25	29	33	37
Body weight (lbs.)	13,200	13,700	14,200	14,700

\* Please call for detailed weight information.

### CYCLE TIMES

Automatic pack/return: 14 seconds  
Crusher panel down/up: 6 seconds

### FEATURES

Wittke is the ultimate in refuse packers. Meet the ULTIMATE Wittke. Everything about the Express series is designed for ease of use, efficiency and safety. With a low loading height, our unibody construction eliminates any leakage between the hopper and the body, and allows easy cleaning, even behind the blade. An extra large hopper door opening accommodates even the bulkiest items. Its six cubic yard hopper volume is large enough to reduce frequent use of the crusher panel, increasing on-route efficiency. The Express Series even comes with an adjustable multicycle automatic pack control. Extended warranties are available, as well as custom options on certain chassis.

Twenty years of ongoing research and development are evident in every operational detail. From its low liftover height, Ultrawear<sup>®</sup> pack slides, to its superior Muncie<sup>®</sup> Live Pak hydraulic pump, the Express Series is the "ultimate" Wittke.

### OPTIONS

- Custom walk-in cab
- Rotary cart lifter
- Rear vision system
- On-board scales
- Dual outside control stations

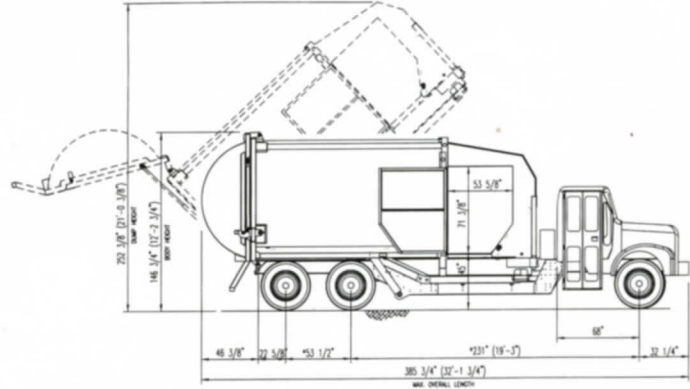

### SPECIFICATIONS

#### Materials:

##### Front Body

- Hopper floor: 1/4" QT 360 AR 100,000 psi yield
- Hopper sides: 1/4" TI A514 100,000 psi yield
- Hopper slope: 1/4" QT 360 AR 100,000 psi yield
- Ram face: 1/4" T1 A514 100,000 psi yield
- Wear surfaces: Ultrawear<sup>®</sup> chromium overlay

##### Main Body

- Body floor: 3/16" A715 80,000 psi yield
- Sides: 10 ga. A715 80,000 psi yield
- Roof: 12 ga. A715 80,000 psi yield
- Longitudinals: 2" x 6" x .250" hollow structural steel
- Tailgate: Skin 10 ga. A715 80,000 psi yield, Sides 3/16" A715 80,000 psi yield

### HYDRAULICS

- Hydraulic pump: Muncie Live Pak
- Control valve: Commercial VA35
- Frame mounted reservoir
- Hydraulic cylinders: Commercial Intertech
- Seamless formed hydraulic tubing
- JIC flair system
- 78,500 lbs of compaction force

### ELECTRICAL

- Vapor proof
- Sealed compression connections
- Reset circuit breakers
- Auto/Man throttle advance
- Reset circuit breakers



Wittke Waste Equipment  
1496 Brier Park Crescent N.W.  
Medicine Hat, Alberta  
Canada T1C 1T8  
Phone 403-527-8806  
Fax 403-529-1821  
Website [wittke.com](http://wittke.com)

U.S. Parts Distribution Depot  
Distribution by:

**WITTKE WASTE EQUIPMENT  
33/37 CU. YD.  
EXPRESS MANUAL SIDE LOADER  
SPECIFICATIONS**

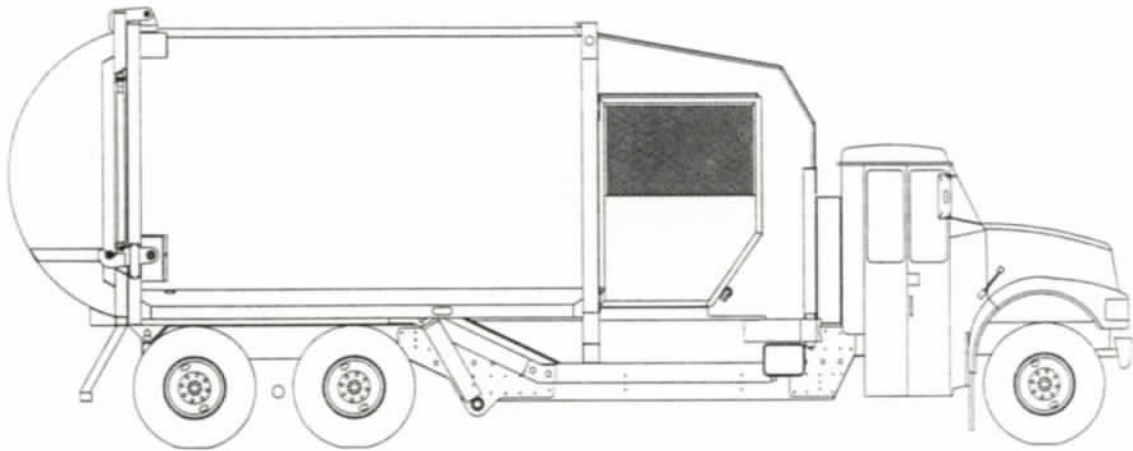

***BODY***

**DIMENSIONS**

OVERALL LENGTH:	298.0"(33 CU. YD.)
OVERALL WIDTH:	101.5"
OVERALL HEIGHT:	106.0"(ABOVE CHASSIS FRAME)
INSIDE WIDTH:	86.0"
INSIDE HEIGHT:	92.0"

**CONSTRUCTION**

FLOOR:	3/16" ASTM A715-80(80,000 PSI YIELD)
SIDES:	10 GAUGE ASTM A715-80
ROOF:	12 GAUGE ASTM A715-80
SILLS:	6" X 2" X .250" HSS

***HOPPER***

**DIMENSIONS**

CAPACITY:	6.0 CU. YD.
LOADING HEIGHT:	5.5"(ABOVE CHASSIS FRAME)
HOPPER WIDTH:	78.0"
HOPPER DEPTH:	18.0"
RAM PENETRATION:	12.0"
SWEPT VOLUME:	1.5 CU. YD.

DOOR WIDTH: 54.7"  
DOOR HEIGHT: 71.0"

CONSTRUCTION

RAM FACE: ¼" ASTM A514(100,000 PSI YIELD)  
FLOOR: ¼" ASTM A514  
SIDES: ¼" ASTM A514  
SLOPE: ¼" ASTM A514  
WEAR PADS, RAM: ULTRA-MET™, ½" THK. X 2 ½", BHN 550  
WEAR PADS, HOPPER: ULTRA-MET™, ½" THK. X 2 ½", BHN 550

**CRUSHER PANEL**

FORMED FROM: 10 GAUGE ASTM A715-80  
ACTUATION: SINGLE CYL., 3.0" BORE, CUSHION ON RET.  
LOCATION: MOUNTED AT FRONT OF HOPPER  
CONTROL: ELECTRIC PUSHBUTTON, UP/DOWN

**TAILGATE**

FORMED FROM: 10 GAUGE ASTM A715-80  
FRAME: 4" X 3" X .250 HSS  
SEAL: COMPRESSED RUBBER BULB,  
18" LIQUID RETENTION HEIGHT  
LIGHTING: ENCLOSED, STAINLESS STEEL MOUNT  
LATCH: AUTOMATIC HYDRAULIC  
SAFETY LATCH: MECHANICAL, STEEL BLOCKS  
SIZE: 5.5 CU. YD.  
OPEN ANGLE: 30° ABOVE HORIZONTAL

**HYDRAULICS**

PUMP: MUNCIE LIVE PAK™, 55 GPM  
RESERVOIR: 50 IMPERIAL GALLONS  
SYSTEM PRESSURE: 2000 PSI  
SUCTION STRAINER: 100 MESH  
RETURN FILTER: 10 μ ABSOLUTE  
LINES: SEAMLESS STEEL TUBING  
HOSES: 10,000 PSI BURST  
PACK CYLINDERS: 5.0" BORE  
TAILGATE CYLINDERS: 2.5" BORE  
HOIST CYLINDERS: 5.0" BORE, SINGLE ACTING TELESCOPIC  
HOIST DUMP ANGLE: 45°

**ELECTRICAL**

WIRING: WATER SEALED  
LIGHTING: CMVSS APPROVED  
CIRCUIT PROTECTION: RESETTABLE CIRCUIT BREAKERS  
CONNECTIONS: CRIMPED & SHRINK WRAPPED AT  
TERMINALS, SOLDERED & SHRINK WRAPPED  
AT SPLICES.

### **CONTROLS**

ACTUATION: ELECTRIC/AIR/HYDRAULIC  
ENGINE SPEEDUP: AUTOMATIC WITH PACK & CRUSH  
STATIONS, STD. IN-CAB & OUTSIDE, CURB SIDE  
STATIONS, OPT. OUTSIDE, STREET SIDE  
STATION: CURB SIDE STD, STREET SIDE AVAIL.  
TYPE, OUTSIDE AUTO PACK  
EMERGENCY STOP  
FORWARD JOG  
REVERSE JOG  
CRUSHER PANEL UP  
CRUSHER PANEL DOWN  
TYPE, IN-CAB PUMP ON/OFF  
MARKER LAMP ON/OFF  
HOIST UP/DOWN  
TAILGATE UP/DOWN  
PACK, SINGLE/CONTINUOUS

### **MISCELLANEOUS STD. EQUIPMENT**

BODY SAFETY PROP  
MUDFLAPS, BEHIND AND AHEAD OF TANDEMS, WITH ANTISAIL RODS

### **FINISH**

METAL PREPARATION: SANDBLAST TO SSPC-SP6, COMMERCIAL  
BLAST  
PRIMER: I.C.I. BRAND, EPOXY  
ENAMEL: I.C.I. BRAND, POLY-  
URETHANE

### **WARRANTY**

BODY: 1 YEAR LIMITED  
HYDRAULIC CYLS: 3 YEAR LIMITED

## WITTKE MANUAL SIDE LOADER STANDARD EQUIPMENT

MS0101	Alarm	Backup, audible warning
MS0201	Filtration	Air supply mist separator for air control system
MS0202		Air supply contaminant filter for air control system
MS0203		Reservoir suction strainer, 100 mesh
MS0204		Reservoir magnetic drain plug
MS0301	Pressure Test Port	Lincoln brand
MS0401	Hose Protective Cover	Steel coil, pack cylinder hoses
MS0402		Rear Hinge hoses
MS0501	Hydraulic Valve	Lock, tailgate open/close motion
MS0502		Restrictor/check, hoist down motion
MS0503		Restrictor, tailgate open/close motion
MS0504		Shutoff, return line, ball style, 1.25"
MS0505		Shutoff, suction line, ball style, 2.50"
MS0601	Mud Flaps	2 pair, with antisail rods
MS0701	Lighting	Marker lamps, FMVSS
MS0702		Stop, turn tail lamps, FMVSS, recessed, lower tailgate, 4 pcs.
MS0703		Backup lamps, recessed, lower tailgate, 2 pcs.
MS0704		Licence plate lamps, lower tailgate, 2 pcs.
MS0705		Mid body signal & marker lamps, 2 pcs.
MS0706		Stop lamp, recessed, center of tailgate, 1 pc.
MS0801	Painting & Finishing	Body, sand blast and prime only
MS0802		Body, first color, polyurethane enamel
MS0803		Conspicuity labeling, F.M.V.S.S. compliant
MS0901	Standard Control Package #1	Hoist, toggle switch, up/down
MS0902		Rear door, toggle switch, open/close
MS0903		Marker lamps, toggle switch, on/off
MS0904		Pump, rocker switch, on/off
MS0905		Pack cycle, toggle switch, single/multi
MS0906		Safety lockout, crusher disabled if packer blade off home position
MS1001	Standard Control Package #2	Pushbutton switch, Auto Pack
MS1002		Pushbutton switch, Emergency Stop
MS1003		Pushbutton switch, Pack forward jog
MS1004		Pushbutton switch, Pack return jog
MS1005		Double toggle switch, crusher panel up/down